

# Table of Contents

- 1. Overview** ..... 3
  - A. Safety Information.....3
  - B. Other Conventions.....5
- 2. Installation** ..... 7
  - A. Overview of Installation .....7
  - B. Required Materials (Not Supplied).....7
  - C. Design the Installation .....7
  - D. Install the Battery Charger.....9
  - E. Install the Order Point Speaker and Microphone Assemblies.....12
  - F. Install the Vehicle Detector(s).....13
  - G. Assemble the 3M™ Drive Thru Headset G5.....13
  - H. Install the Basestation.....15
  - I. Connect the Components.....17
  - J. Basestation to Component Wiring .....20
  - K. Auxiliary Detector Relays.....21
  - L. Installing Accessory Boards in the Basestation.....23
  - M. Power Up .....26
- 3. Configuration** ..... 28
  - A. Enter Configuration Mode.....28
  - B. Navigating the Basestation Display.....28
  - C. Finding the MAC Address of the G5 Basestation.....30
  - D. Configuring with a Computer .....30
  - E. Logging into the Base Station with a PC.....31
  - F. Switching Between Lane1 and Lane2 .....31
  - G. Menu Options for Lane1 and Lane2 .....32
  - H. Change Basic Volume Settings.....33
  - I. Change Noise Reduction Level.....39
  - J. Set System Date and Time.....39
  - K. Change Global Settings.....39
  - L. Haptics “Vibration” Alerts and Blue LED Alerts on Headsets.....42
  - M. Order Taking Modes Setup .....43
  - N. Change Site Scheduling .....43
  - O. Change Site Information .....44
  - P. Digital IO Setup .....45
  - Q. Change Passcodes .....45
  - R. Split and Cross Lane Mode.....46
  - S. Installer Setup .....46
  - T. Factory Setup (Restore Factory Defaults).....47
  - U. Create and Load Templates .....47
  - V. Reboot System.....47
  - W. Check the Revision Levels .....48
- 4. Troubleshooting** ..... 49

- A. Headset Indicator Lights ..... 49
- B. General Troubleshooting ..... 51
- C. Battery and Battery Charger Troubleshooting ..... 54
- 5. Appendix: Declaration of Conformity** ..... 56
- 6. Appendix: Basestation Specifications** ..... 63
  - A. Physical ..... 63
  - B. Electrical ..... 63
  - C. Functional ..... 63
  - D. Antennas ..... 63
  - E. Magnetic Loop Detectors ..... 63
- 7. Appendix: Induction Loop and Vehicle Detector Board Specifications** . . . 64
  - A. Internal Vehicle Detector Board Specifications ..... 64
  - B. Saw - In Loop Specifications ..... 64
  - C. Prefab Loop Specifications ..... 64
- 8. Appendix: G5 Charger Specifications** ..... 65
  - A. Physical ..... 65
  - B. Electrical ..... 65
  - C. Functional ..... 65
- 9. Appendix: Best Practices** ..... 66
  - A. PreAmp Setting ..... 66
  - B. Volume Control ..... 66
  - C. Optimizing Installation ..... 66
  - D. Dealing with Delay/Echo ..... 67
- 10. Appendix: 3M™ Acoustic Kit Installation Guide** ..... 68
  - A. System Components ..... 68
  - B. Installation Guidelines - Separate Housings ..... 68
  - C. Installation Guidelines - Single Housing ..... 69
- 11. Appendix: Loop and Cable Condition Test** ..... 71
  - A. Lineal Conductor Resistance and Inductance ..... 71
  - B. Insulation Resistance ..... 71
- 12. Appendix: Upgrading a Single Lane Basestation to a Dual Lane** ..... 72

## 1. Overview

### A. Safety Information

#### Safety Rules

Read, understand, and follow all safety information contained in these instructions prior to installation & operation of G5 Basestation Model G5B1, XT-1 Headsets and the 3M™ Drive Thru Headset G5. Failure to follow all instructions listed could result in electrical shock, fire and/or other personal injury. Retain these instructions for future reference.

#### Intended Use

G5 Basestation Model G5B1, XT-1 Headsets and the 3M™ Drive Thru Headset G5 are intended for use to provide 2-way radio-frequency audio communication in quick service drive-through restaurants and convenience stores.

This system requires professional installation by 3M authorized service personnel only and must be installed as specified in G5 Basestation Model G5B1 Installation Instructions and operated as specified in G5 Basestation Model G5B1 Operating Instructions in quick service drive-through restaurants and convenience stores. It has not been evaluated for other uses or locations.

#### Signal Words

##### **WARNING**

Indicates a potentially hazardous situation, which, if not avoided, could result in death or serious injury and/or property damage.

##### **CAUTION**

Indicates a potentially hazardous situation which, if not avoided, could result in minor or moderate injury and/or property damage.

##### **IMPORTANT NOTE**

Indicates a potentially hazardous situation, which, if not avoided, may result in property damage. It is strongly recommended that you pay attention to information inside of an Important Note.

#### System Warnings

##### **WARNING**

To reduce the risk associated with hazardous voltage:

- Disconnect power to the receptacle before installing or removing the Basestation Power Supply. When removing receptacle cover screw, cover may fall across plug pins or receptacle may become displaced. Use only with duplex receptacle having center screw. Secure unit in place by receptacle cover screw.
- If power supply is supplied with a grounding pin, connect directly to a grounding receptacle – 3 prong.
- Do not use G5 Basestation Model G5B1 or XT-1 Battery Charger, G5 Battery Charger or G5 Headset Charger, if the power supply cord or enclosure is damaged.
- Use the power supply indoors and in dry locations only.

## **WARNING**

To reduce the risks associated with fire, explosion & property damage:

- Immediately discontinue use of the battery if, at any time, the battery feels hot, changes color or shape, emits an unusual smell, or appears abnormal or damaged in any other way.
- Do not open, disassemble, pierce, crack, crush, incinerate, or expose to heat above 55 °C/130 °F. Keep batteries away from children.
- Do not store or carry batteries with metal objects. Store batteries in cool, dry, clean places.
- Always replace batteries, battery chargers and power supplies, and all other system components with only 3M approved units acceptable for use in this system to avoid system malfunction and safety concerns. Replace model XT-1 battery with Model C1060/XT-1 only. Replace model G5 battery with Model G5L1 3M only. Use of another battery may present a risk of fire or explosion.
- Do not immerse batteries in water or other liquids.
- Do not use batteries that feel hot or that have changed in color or shape, emit an unusual smell, or appear damaged or abnormal in any other way.
- Discontinue use if damage or abnormalities are observed. Conduct regular visual inspections of batteries to look for damage or abnormalities, such as changes in shape or color.
- Use only 3M-approved batteries.
- The 3M™ Drive-Thru Headset Battery Charger, G5 12-slot and the 3M™ Drive-Thru Headset Charging Station, G5 are supplied with two power connections to allow for connecting an additional charger and/or base station. During installation, do not connect more than one power supply to one charger, or to the interconnected string of chargers.
- Do not modify this 3M™ Wireless Communication System Model XT-1, or 3M™ Wireless Communication System Model G5.
- For additional charging and use instructions, review the Installation Manual and the Operating Instructions.

## **CAUTION**

To reduce the risks associated with environmental contamination due to battery pack:

- Dispose of batteries, power supplies, battery charger and base station in accordance with federal, state & local requirements. If preferred, return these components to 3M Service Center for recycle.
- Many rechargeable batteries are required to be recycled by local, state/province, and national laws. To properly recycle/dispose of the battery or battery pack, always follow local solid waste disposal regulations. Additionally, in the United States and Canada, 3M is partnering with Call2Recycle (RBRC) to provide recycling service to you to help ensure that the rechargeable batteries within our products are recycled properly. To assist you in using this service call the Call2Recycle battery recycling information help line at 1-800-8-BATTERY (1-800-822-8837) or consult Call2Recycle's battery recycling guidance online at [www.call2recycle.org](http://www.call2recycle.org).

## B. Other Conventions

### FCC and Industry Canada Information

#### IMPORTANT NOTE

##### **FCC RF Exposure Statement:**

XT-1 Headset and the 3M™ Drive Thru Headset G5 comply with FCC RF radiation exposure limits set forth for an uncontrolled environment when operating based on time-averaged output power with duty cycle not to exceed 7.63% with a separation distance of 25mm. The wireless system must not be co-located or operating in conjunction with any other antenna or transmitter.

The G5 Basestation Model G5B1 complies with FCC RF radiation exposure limits. This equipment should be installed and operated with a minimum distance of 20cm between the radiator and your body. This includes any 3M approved external antenna.

The use of accessories not approved by 3M Company, including but not limited to batteries, antennas, wall adapters, chargers, ear pads and foam tips and convertible covers, may cause your headset or Basestation to malfunction or in the case of unapproved electrical accessories and antennas may cause the device to exceed RF energy exposure guidelines.

##### **FCC Note:**

This equipment has been tested and found to comply with the limits for a Class A digital device, pursuant to part 15 of the FCC Rules. These limits are designed to provide reasonable protection against harmful interference when the equipment is operated in a commercial environment. This equipment generates, uses, and can radiate radio frequency energy and, if not installed and used in accordance with the instruction manual, may cause harmful interference to radio communications. Operation of this equipment in a residential area is likely to cause harmful interference in which case the user will be required to correct the interference at his own expense.

##### **Canada Note:** CAN ICES-3 A/NMB-3 A

This device complies with part 15 of the FCC Rules and with Industry Canada license-exempt standard RSS-210 as of the date printed. Operation is subject to the following two conditions: (1) this device may cause interference, and (2) this device must accept any interference, including interference that may cause undesired operation of the device.

Cet appareil est conforme avec la norme RSS-210 d'Industrie Canada exempte de licence à compter de la date imprimée. Son fonctionnement est soumis aux deux conditions suivantes : (1) cet appareil peut causer des interférences, et (2) cet appareil doit accepter toute interférence, y compris celles pouvant provoquer un fonctionnement indésirable de l'appareil.

# 3M™ Drive-Thru System Model G5

## FCC and IC Identifiers:

XT-1 Headset:

FCC ID: DGFBCSDXT1H

IC ID: 458A-BCSDXT1H

G5 Basestation Model G5B1:

FCC ID: DGFBCSDG5B1

IC ID: 458A-BCSDG5B1

3M™ Drive-Thru Headset G5:

FCC ID: DGFBCSDG5H1

IC ID: 458A-BCSDG5H1

### **IMPORTANT NOTE**

Modifications to this device shall not be made without the written consent of 3M Company. Unauthorized modifications may void the authority granted under Federal Communication Rules and Industry Canada Rules permitting the operation of this device.

## Recycling / Disposal (Notice to European Union customers)



These products must be disposed respectively recycled at the end of their lifetime according to the till then mandatory laws and rules.



Under European Union (“EU”) Directive on Waste Electrical and Electronic Equipment, Directive 2012/19/EU products of “electrical and electronic equipment cannot be discarded as municipal waste anymore and manufacturers of covered electronic equipment will be obligated to take back such products as the end of their useful life. For appropriate disposal and recycling instructions, contact your local 3M representative.



## European Union CE Information

### **IMPORTANT NOTE**

To ensure that the maximum 20 dBm EIRP output power is not exceeded, for any 3M approved external antenna that is used with the G5 Basestation Model G5B1, the minimum length of RF cable required is 100 feet.

## 2. Installation

### A. Overview of Installation

Installation involves the following main steps:

1. Design the installation
2. Install the battery charger and begin charging the batteries.
3. Install the order point speaker and microphone assemblies.
4. Install the base station(s).
5. Install the vehicle detector loop(s).
6. Wire Greeter Alert trigger inputs
7. Power up the basestation
8. Configure the System and Greeter

### B. Required Materials (Not Supplied)

- Standard or surface-mount conduit (metal or plastic) to enclose all system wiring.
- Assortment of sheet metal screws and wall anchors.
- Sufficient 18 to 20 AWG, (1.02 to 0.81mm diameter) shielded twisted pair audio cable, sufficient in length to connect the speaker and microphone assembly from the order point to the base station.
- Recommend basic tool kit - screw drivers, pliers, wire strippers, crimping tools, scissors, soldering iron, solder, crimp caps, electrical tape, wire ties, etc.

#### IMPORTANT NOTE

The twisted pair of wires for the microphone connection must be shielded for proper operation. In duplex systems, microphone and speaker cannot be in the same jacket unless specially designed for duplex such as 3M™ Cable part number 78-8117-4313-3.

- Sufficient shielded twisted-pairs of audio cable to connect other components such as grill monitor speaker, vehicle detection device, etc.

### C. Design the Installation

There are multiple ways to install the intercom system. Before you begin you must understand how many components you will be installing and where they must be installed. Use the installation checklist (if available) and these instructions to assist you in designing the system.

#### Determine the Drive-Thru Type(s)

Following is a brief description of each drive-thru type:

- A *Single Drive-Thru* (see Figure 1) is the most common configuration. It is comprised of one lane of traffic with one order point, and one or two drive-thru windows for payment and pick up.

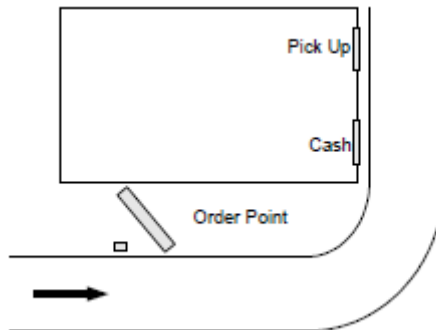

**Figure 1.**

- A *Tandem Drive-Thru* (see Figure 2) is comprised of a single lane of traffic with two order points (one in front of the other) and one or two drive-thru windows for payment and pick up.

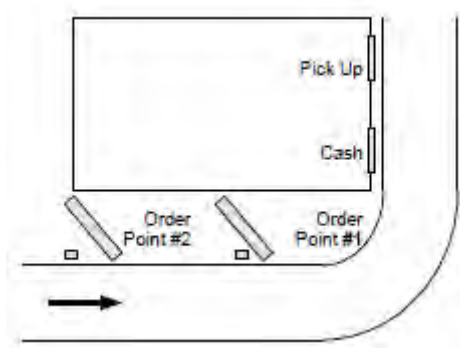

**Figure 2.**

- A *Side-by-Side Drive-Thru*, (See Figure 3) also known as a “Y” or “Merge” drive-thru, is comprised of two lanes of ordering traffic side-by-side, each with its own ordering point, but merges into a single lane with one or two drive-thru windows for payment and pick up.

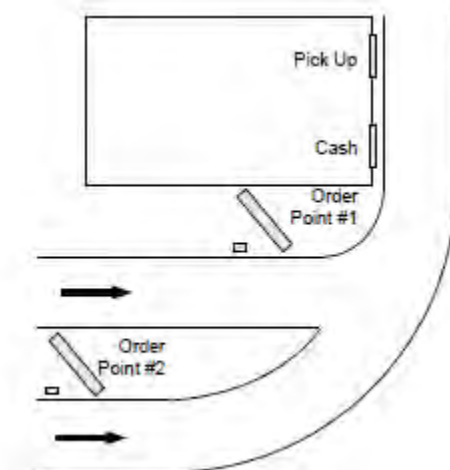

**Figure 3.**



- A *Dual Drive-Thru* (see Figure 4) is comprised of two completely separate drive-thru systems, each with its own lane, usually on opposite sides of the building, its own order point, and one or two drive-thru windows for payment and pick up. The simplest dual drive-thru is two single drive-thrus, but it is possible to have dual tandem, dual side-by-side, or even a combination of different drive-thru types.

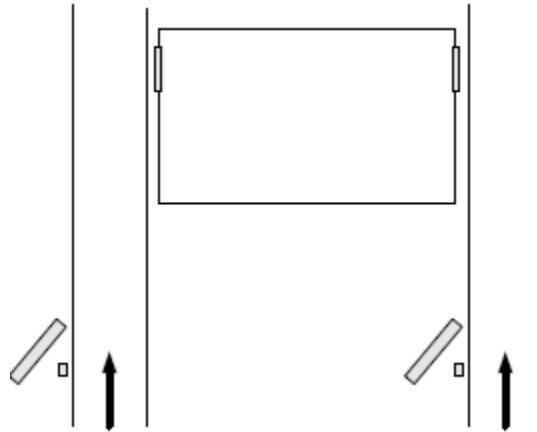

**Figure 4.**

## Number and Configuration of Basestations

Only one G5 Basestation Model G5B1 is required to support a Single Lane or Dual Lane operation. Single Lane basestations do not have the Dual Lane functionality activated. Dual Lane basestations come with Dual Lane functionality already enabled at factory.

Regardless of the type of Dual Lane, in the event you are attempting to upgrade a previously purchased Single Lane basestation to operate in Dual Lane, the basestation's Dual Lane functionality must be activated. To activate this Dual Lane functionality, you must purchase the 3M™ Drive-Thru System G5 Dual Lane Upgrade Package SKU# 78-6911-5206-6. See "Appendix: Upgrading a Single Lane Basestation to a Dual Lane" on page 72, on how to upgrade from a Single to a Dual with the software purchase.

## Number and Type of Vehicle Detectors

G5 Basestation Model G5B1 can accommodate up to two vehicle detectors; one for each Lane's Order Point.

There are two basic types of vehicle detector output signal: presence and pulse.

- Presence detectors are most common. They tell the base station when a vehicle is present over the detector. They remain active as long as the vehicle stays within the range of detection.
- Pulse detectors are less common. They tell the base station when a vehicle has arrived, but have no mechanism to know if or when the vehicle leaves. An air hose is typically used to provide the pulse signal when a vehicle rolls over it.

## D. Install the Battery Charger

The G5 headset batteries can be charged while the battery is still in the headset using the G5 Headset Charging Station G5 or separately using a standalone 3M™ Drive-thru Headset Battery Charger, G5 12-slot. All lights and indications will flash on the battery and not on the chargers.

The XT-1 headset uses the 6-slot or 3-slot battery charger.

## 3M™ Drive-thru Headset Battery Charger, G5 12-Slot

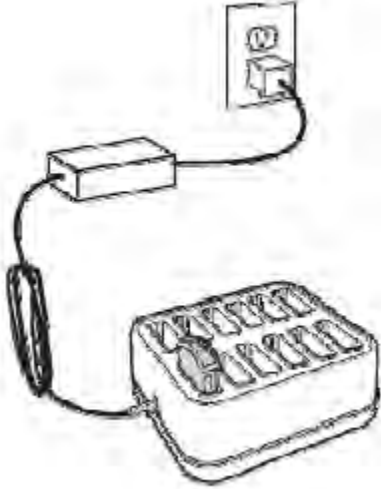

**Figure 5.**

The battery charger uses the same power adapter as the basestation. Perform the following steps to install and use the 12-slot battery charger.

- Select a placement location, either:
  - A flat, dry surface such as a desktop or shelf.
  - An easy-to-reach wall.
- The power outlet must be near the equipment and be accessible, and cord placed where it cannot be pinched or bent.
- If wall mounting is to be used: Due to the many different wall types available, hardware is not included. Secure the product to the wall with anchors suitable for the type of wall, and which can support a 1.3lb/0.6kg minimum load.
- Place the charger on the surface.
- Connect the 3M supplied power adapter between the wall receptacle and the charger.
- Insert each battery to be charged into a slot on the charger. The LED lights on the battery will light up indicating the level of charge. Each LED indicates a charge of 25%. When all LEDs are lit steady green, the battery is fully charged.
- When charging is complete, the batteries are ready for use.

## 3M™ Drive-Thru Headset Charging Station, G5

Headset Charging Station, G5 uses the same power adapter as the basestation. Perform the following steps to install and use the Headset Charging Station, G5:

- Select a placement location, either
  - A flat, dry surface such as a desktop or shelf.
  - An easy-to-reach wall.
- The power outlet must be near the equipment and be accessible, and cord placed where it cannot be pinched or bent.
- If wall mounting is to be used: Due to the many different wall types available, hardware is not included. Secure the product to the wall with anchors suitable for the type of wall, and which can support a 2.9lb/1.3kg minimum load.
- Place the charger on the surface.
- Connect the 3M supplied power adaptor between the wall receptacle and the charger.
- Insert a G5 Headset (with a G5 battery in it) into the Headset bay on the charger.
- Alternatively, you may insert the G5 battery to be charged into a slot on battery bay of the charger.
- The LED lights on the battery will light up indicating the level of charge. Each LED indicates a charge of 25%. When all LEDs are lit green, the battery is fully charged.

- When charging is complete, the batteries are ready for use.

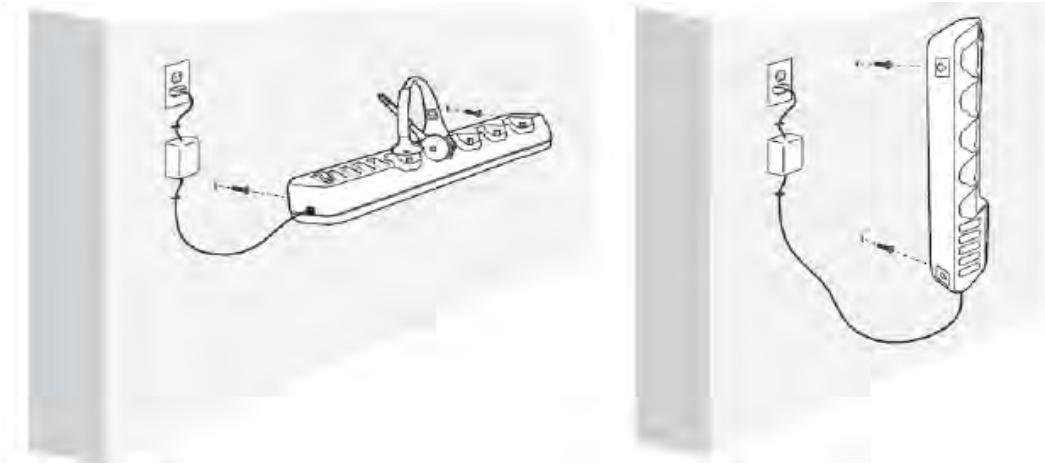

**Figure 6.**

**(i) IMPORTANT NOTE**

Power plugs are available on both sides of the stand-alone Battery Charger, G5, 12-slot to allow a connection to one additional Battery Charger, G5, 12-slot or a Headset Charging Station, G5 in serial using a patch cable.

You may also use the power plug on the last charger in the interconnected chain to supply power to the basestation.

**(i) IMPORTANT NOTE**

Both types of battery chargers can be mounted on the wall. Due to the many different wall types available, hardware is not included. Hardware or anchors used for wall mounting must be suitable for the wall type, and be capable of supporting a 2.9lb/1.3kg minimum load for the 3M™ Drive-Thru Headset Charging Station, G5, and a 1.3lb/0.6kg minimum load for the 3M™ Drive-thru Headset Battery Charger, G5 12-slot.

## XT-1 6-Slot or 3-Slot Battery Charger

Perform the following steps to install and use the 6-slot or 3-slot battery charger (see Figure 7).

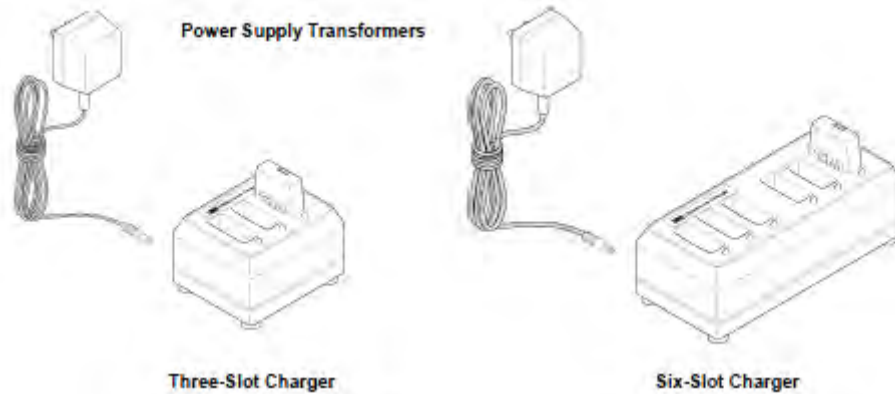

**Figure 7.**

- Select a placement location:
  - A flat, dry surface such as a desktop or shelf.
  - An easy-to-reach wall location if you have the optional wall-mount bracket.
- The power cord should be in place where it cannot be pinched or bent
- Install the wall-mount bracket on the wall, if applicable.
- Place the charger on the wall-mount bracket or surface.
- Connect the power supply transformer between the wall receptacle and the charger. The charge indicator lights will flash.
- Insert each battery to be charged into a slot on the charger. The charge indicator lights for each slot will light steadily red to indicate that the battery is charging or green to indicate that the battery is fully charged.
- When charging is complete, the batteries are ready for use.

### **(i) IMPORTANT NOTE**

A fully discharged (dead) battery can take as long as 3 ½ hours to recharge. Fully charged batteries should be stored whenever they are not in use. Leaving them on the charger does not harm them or waste energy.

## **E. Install the Order Point Speaker and Microphone Assemblies**

Use the recommended speaker and microphone systems listed below and follow the included instructions:

- 3M™ Microphone Assembly. Part # 78-6911-4935-1
- 3M™ Speaker Assembly, Duplex, 5 inch. Part # 78-6911-4411-3
- 3M™ Speaker Assembly, Duplex, 4 in 78-6911-5202-5
- 3M™ Microphone Duplex, Foam block assembly 78-6911-5201-7

For information on wiring the speaker and microphone to the base station, see “Basestation to Component Wiring” on page 20.

### **(i) IMPORTANT NOTE**

Solder and insulate, using heat shrinkable crimp caps, all connections including loop, microphone and speaker.

When using Part # 78-6911-4935-1 and Part # 78-6911-4411-3 for Microphone and Speaker, respectively, it is recommended that the two be acoustically separated by treating the speaker post with the 3M Acoustic Kit. For more information refer to “Appendix: 3M™ Acoustic Kit Installation Guide” on page 68.

## F. Install the Vehicle Detector(s)

Follow the instructions provided with the vehicle detectors for installing the detector loop(s), speakers, and microphones.

For information on wiring and configuring the vehicle detector(s) to the basestation see see “Basestation to Component Wiring” on page 20.

For information on installing the vehicle detector circuit boards in the basestation, see “Installing Accessory Boards in the Basestation” on page 23.

## G. Assemble the 3M™ Drive Thru Headset G5

The components that make up a 3M™ Drive Thru Headset G5 are packaged and shipped as individual parts:

- 3M™ Control Pod, G5 (includes a pack of ID Tags)
- 3M™ Carrier, G5 (includes a pack of ID Tags) and
- 3M™ Battery, G5

Use the instructions below to assemble these parts to make a fully functional headset.

### Installing ID Tags

In 3M™ drive-thru systems with Reminder and Alert features in V5 release software installed, you can (by installing ID tags on each headset) easily

- Assign and identify headsets to crew members
- Attend to hygiene concerns

Each Control Pod and Carrier shipped has a bag enclosed with 8 different colored tags that can be interchanged by the staff. The Control Pod and Carrier come pre-installed with Black ID Tags. The colors included in the bag are:

Red, Green, Blue, Yellow, Purple, Black, White, Orange, Pink

Follow the procedure below to install ID Tags:

- **Control Pod**

Remove the existing ID Tag from the Control Pod, replace with the color of your choice. Gently apply pressure (using the tip of a ball point pen, for example) so the ID Tag securely holds its position.

- **Carrier**

Flip open the Head Pad as shown below.

From the outside, gently push the ID Tag out. Replace this Tag with one of your choice from the bag of ID Tags. After removing the ID Tag replace with the color of your choice, gently apply pressure (using the tip of a ball point pen, for example) so the ID Tag securely holds its position.

Close the Head Pad.



Figure 8.

## Assembling the Control Pod and Carrier

Follow the procedure below to assemble the Control Pod and Carrier to form a fully functional headset:

1. On the opposite side of the Headset Carrier, ensure that the Control Pod Locking Mechanism is in the unlocked position by sliding it all the way to the left. A small flat head screwdriver or other similar tool can be used to slide the locking mechanism if needed. See Figure 9 below.
2. Align Charging Contact Block on Control Pod into the Charging Contact Block Receptacle of the Headset Carrier. Once the Charging Contact Block is set into in the Receptacle it will act as hinge or pivot point. See Figure 10.
3. Gently press the two halves together until they securely snap into place at the top. You may need to apply a slight downward pressure to align the connections appropriately. When the Control pod is connected to Carrier you will hear a slight click sound. See Figure 10.
4. Slide locking mechanism on opposite side of carrier to the locked position. See Figure 9.
5. Insert battery into the now assembled headset. See Figure 11.
6. LED indicator lights on the Headset should start blinking (refer to component Identification and Description section below). The headset is now ready for registrations to a basestation.

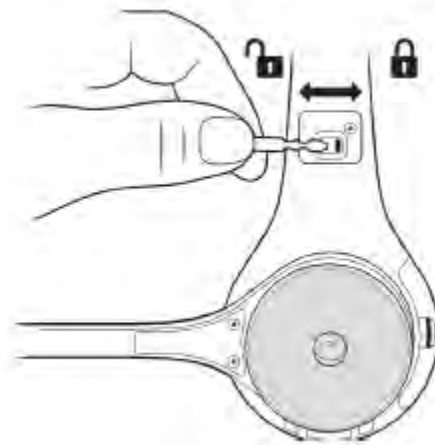

Figure 9.

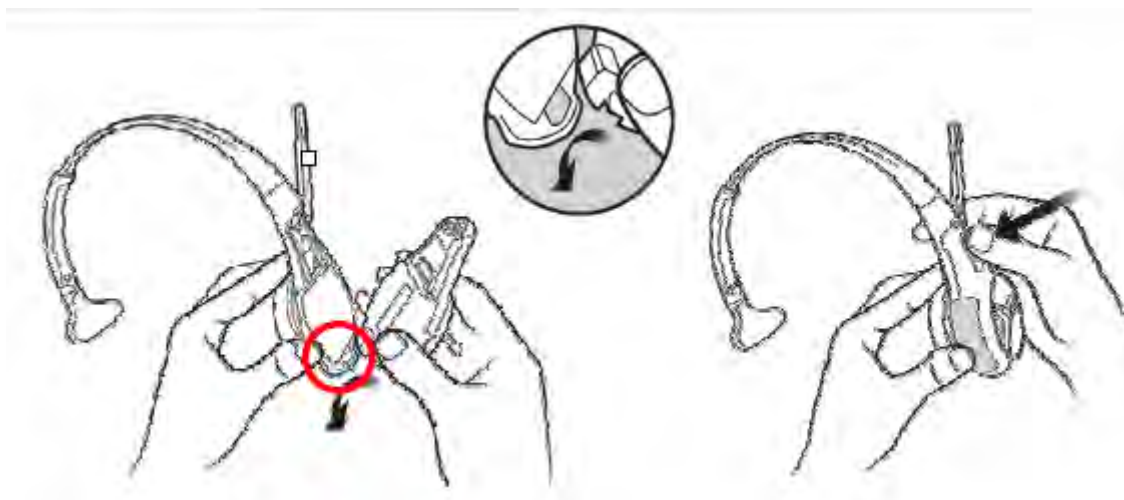

Figure 10.



**Figure 11.**

## H. Install the Basestation

### Choose a Location

Generally, the base station should be located centrally, and close to the order takers. However there are several important guidelines that must be followed to reduce the risk of problems. Follow the guidelines to ensure that the basestation(s) can communicate with headsets in any foreseeable location:

- Do not assume that the location of an old basestation is suitable for a new basestation.
- The LCD screen should be approximately 5 ft (1.5 m) from the floor.
- The basestation should be at least 3 ft (1 m) from large metallic fixtures or appliances.
- The basestation should be within 6 ft (2 m) of a 110VAC, 15A or 20A electrical outlet.
- The basestation should be placed away from inside corners, airborne grease, and moisture.
- Easily visible and the keypad accessible.

### Pre-Testing the Location

Before you permanently mount the base station(s), one person can pre-test the signal using the following procedure:

- Temporarily mount the basestation where you think it may have good range.
- Power the basestation.
- Register two headsets.
- Change the order taking mode to Always On.
- Put on two headsets.
- Tap the talk button on one of the headsets.
- Walk around the location, talking as you walk.
  - If you can hear yourself in the other headset in all desirable order-taker positions, the basestation is in a suitable location.
  - If you cannot hear yourself in the other headset in all desirable order-taker positions, the basestation should be moved to a different location.

### **i** IMPORTANT NOTE

To ensure the best operating range for your system, locate the basestation where it is not within three feet of or blocked by large steel structures such as doors, walls, or large appliances.

If you plan to use an outside order taker, be sure that the basestation's range includes the outside order taker location.

If the best location you find is still unable to communicate to all areas, you may need to install an external antenna.

## Removing and Replacing the Cover

To remove the basestation cover:

- Disconnect power from the basestation.
- Loosen the two screws located at the bottom of the cover.
- Lift the cover upward and away. The display and keypad remain with the base, not with the cover.

To replace the basestation cover:

- Verify there are no obstructions (tools, etc.) in the way of the cover being closed.
- Align the top edge of the cover with the base.
- Swing the bottom half of the cover down into place and gently push it against the base until it locks into place. Tighten the two screws located at the bottom of the cover.

## Mount the Station

Perform the following procedure to install the basestation (See Figure 12).

- Remove the base station cover:

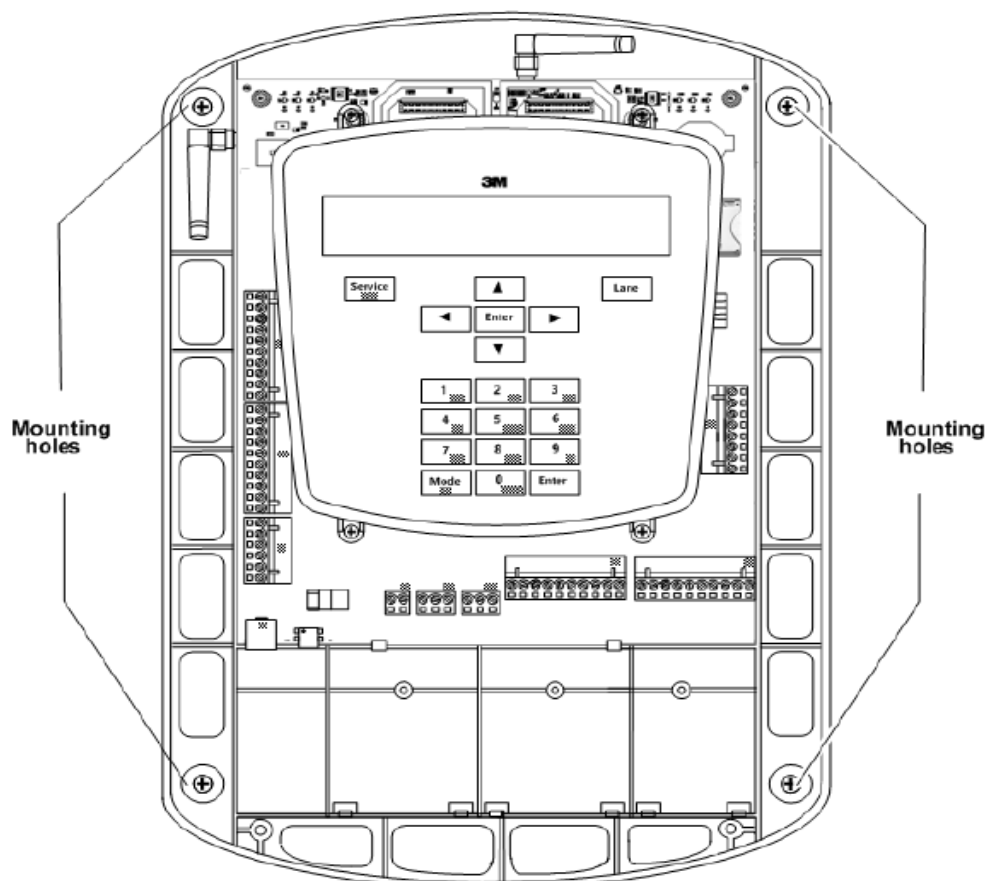

**Figure 12.**

- Attach the basestation to the wall using screws and possibly wall anchors.
- The power outlet must be near the equipment and be accessible, and cord placed where it cannot be pinched or bent.
- Due to the many different wall types available, hardware is not included. Secure the product to the wall with anchors suitable for the wall type, and which can support a 4.0lb/1.8kg minimum load.



The steps below assume that all of the communication cabling has been prepared and is available at the basestation. If not, see “Basestation to Component Wiring” on page 20.

- Follow local best practices and any applicable regulations to route the cables into the basestation cabinet’s top, sides, or back (through the wall) as neatly as possible. Do not route power supply wiring with communication wiring in the same conduit.
- Attach all cables to their appropriate terminals.
- Connect the basestation transformer between the wall outlet and the basestation power supply connection.

## I. Connect the Components

This section provides diagrams and information that should help you to properly wire the system components together.

### Basestation Wiring Terminal Identification

Figure 13 identifies all of the wiring terminals and their labels. The table that follows provides definitions of the labels and identifies where they should be connected in the system.

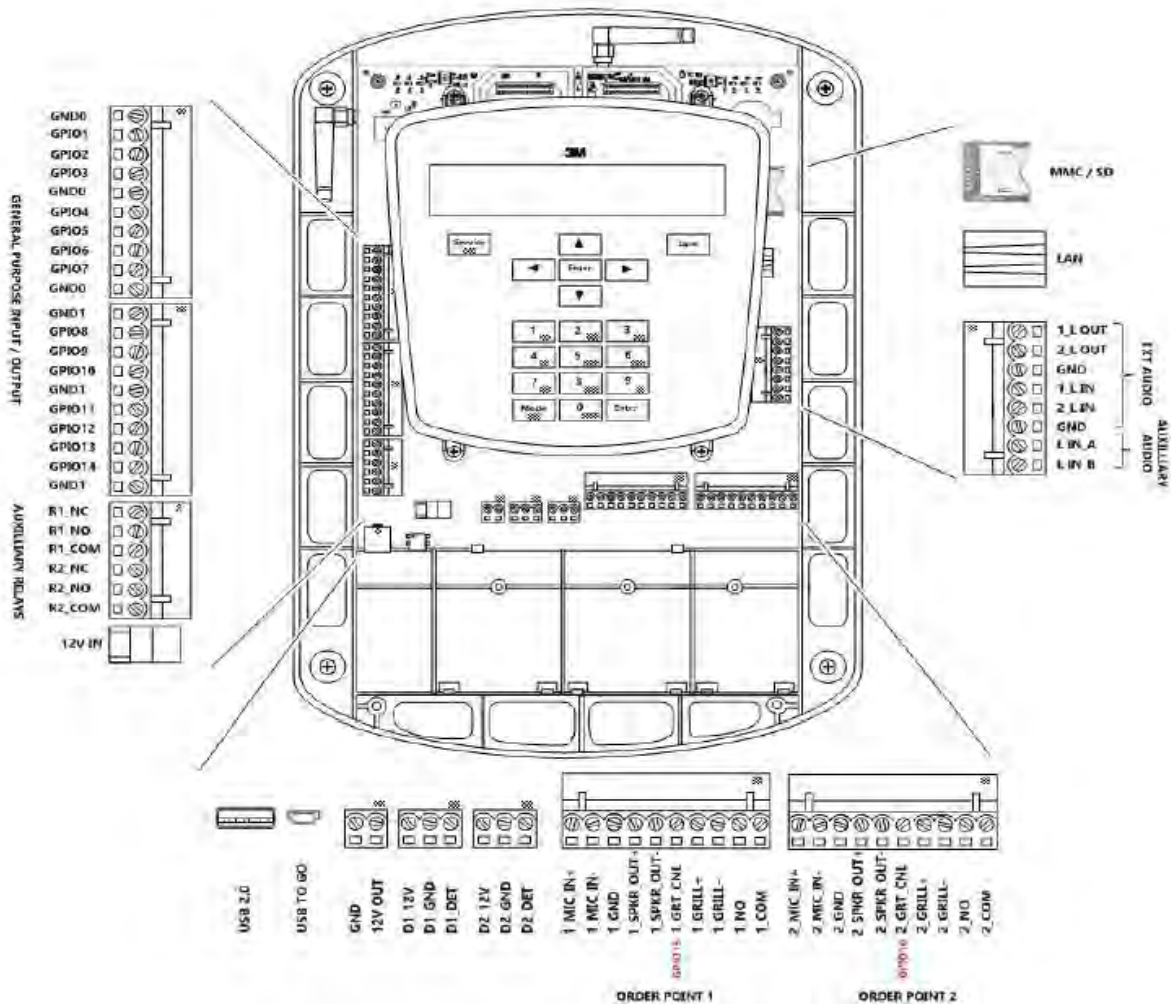

Figure 13.

**Table A. GENERAL PURPOSE INPUT / OUTPUTs (GPIOs)**

16 configurable logical Inputs and Outputs. All Inputs and Outputs are Active Low and are factory set to the following signals. You can reassign any of these GPIOs to output or take as input a different signal. The GPIOs 15 and 16 are logically mapped to the 1\_GRT\_CNL and 2\_GRT\_CNL of Lan1 and Lane2 connectors respectively. You will have to use the GND0 or GND1 from the GPIO terminal block.

Terminal Label	Definition and Connection Information
GND0	Ground
GPIO1	SPLIT/CROSS
GPIO2	ORDER TAKING
GPIO3	DAY/NIGHT
GND0	Ground
GPIO4	EXT_MSG
GPIO5	Cooler Open
GPIO6	Door Open
GPIO7	Unused
GND0	Ground
GND1	Ground
GPIO8	VEH_APP_1
GPIO9	VEH_APP_2
GPIO10	Unused
GND1	Ground
GPIO11	TALK_1
GPIO12	PAGE_1
GPIO13	TALK_2
GPIO14	PAGE_2
GND1	Ground
<b>AUXILLIARY RELAYS: Two SPDT Relays corresponding to the two Vehicle Detectors. Allows for integration of 3rd party accessories. Alternatively, these terminals can be configured via Digital IO Setup in the System Menu to provide the Active Low TALK, PAGE and/or Greet Cancel signal.</b>	
RELAY1_COM	Relay 1 common
RELAY1_NO	Connect to relay 1 if normally open relay
RELAY1_NC	Connect to relay 1 if normally closed relay
RELAY2_COM	Relay 2 common
RELAY2_NO	Connect to relay 2 if normally open
RELAY2_NC	Connect to relay 2 if normally closed
12V IN	Incoming power supply from the transformer
GND	Ground
12V OUT	12 VDC power supply
<b>ORDER POINT-1: All wires from this terminal block go to the Lane1 order point or monitor speaker</b>	
1_MIC_IN+	Positive phase microphone wire for Lane 1
1_MIC_IN-	Negative phase microphone wire for Lane 1
1_GND	Microphone wire shielding for Lane 1
1_SPKR_OUT+	Positive phase order point speaker for Lane 1

Terminal Label	Definition and Connection Information
<b>1_SPKR_OUT-</b>	Negative phase order point speaker for Lane 1
<b>1_GRT_CNL</b>	(GPIO15) Active low talk. Must use one of the GND0 or GND1 from GPIO terminal block.
<b>1_GRILL+</b>	Positive phase grill monitor speaker for Lane 1
<b>1_GRILL-</b>	Negative phase grill monitor speaker for Lane 1
<b>1_NO</b>	Connect to relay 1 if normally open relay
<b>1_COM</b>	Relay 1 common
<b>ORDER POINT-2: All wires from this terminal block go to the Lane1 order point or monitor speaker</b>	
<b>2_MIC_IN+</b>	Positive phase microphone wire for Lane 2
<b>2_MIC_IN-</b>	Negative phase microphone wire for Lane 2
<b>2_GND</b>	Microphone wire shielding for Lane 2
<b>2_SPKR_OUT+</b>	Positive phase order point speaker for Lane 2
<b>2_SPKR_OUT-</b>	Negative phase order point speaker for Lane 2
<b>2_GRT_CNL</b>	(GPIO16) Active low talk. Must use one of the GND0 or GND1 from GPIO terminal block
<b>2_GRILL+</b>	Positive phase grill monitor speaker for Lane 2
<b>2_GRILL-</b>	Negative phase grill monitor speaker for Lane 2
<b>2_NO</b>	Connect to relay 2 if normally open relay
<b>2_COM</b>	Relay 2 common
<b>EXT_AUDIO: 4 auxiliary, 'line level', audio ports. All of the wires on this terminal block go to the external audio</b>	
<b>1_LOUT</b>	Connects to IN on external device. Allows amplification/recording of all Lane 1 audio channels (Inbound, Outbound, PAGE)
<b>2_LOUT</b>	Connects to IN on external device. Allows amplification/recording of all Lane 2 audio channels (Inbound, Outbound, PAGE)
<b>GND</b>	Ground
<b>1_LIN</b>	Connects to OUT on external device. Audio can be used to record Greeter Message for Lane 1 and to provide audio to Lane#2 Headsets/Grill Speaker.
<b>2_LIN</b>	Connects to OUT on external device. Audio can be used to record Greeter Message for Lane 2 and to provide audio to Lane#2 Headsets/Grill Speaker.
<b>GND</b>	Ground
<b>AUXILLIARY AUDIO:</b>	
<b>L IN_A</b>	
<b>L IN_B</b>	
<b>LAN</b>	Network connection (crossover cable to PC or patch cable to network)

## J. Basestation to Component Wiring

### Good Wiring Practices

To reduce interference and improve signal quality, use the following practices for all communication wiring:

- Keep shielding on the cable as close to the terminal as possible.
- Do not untwist pairs more than necessary.
- Do not allow cable strands to fray.
- Do not tin cable leads with solder.
- Fold un-insulated wire over onto itself before inserting into a terminal.
- Make sure screw terminals are tight.

A minimal, typical arrangement of the components is shown in Figure 14:

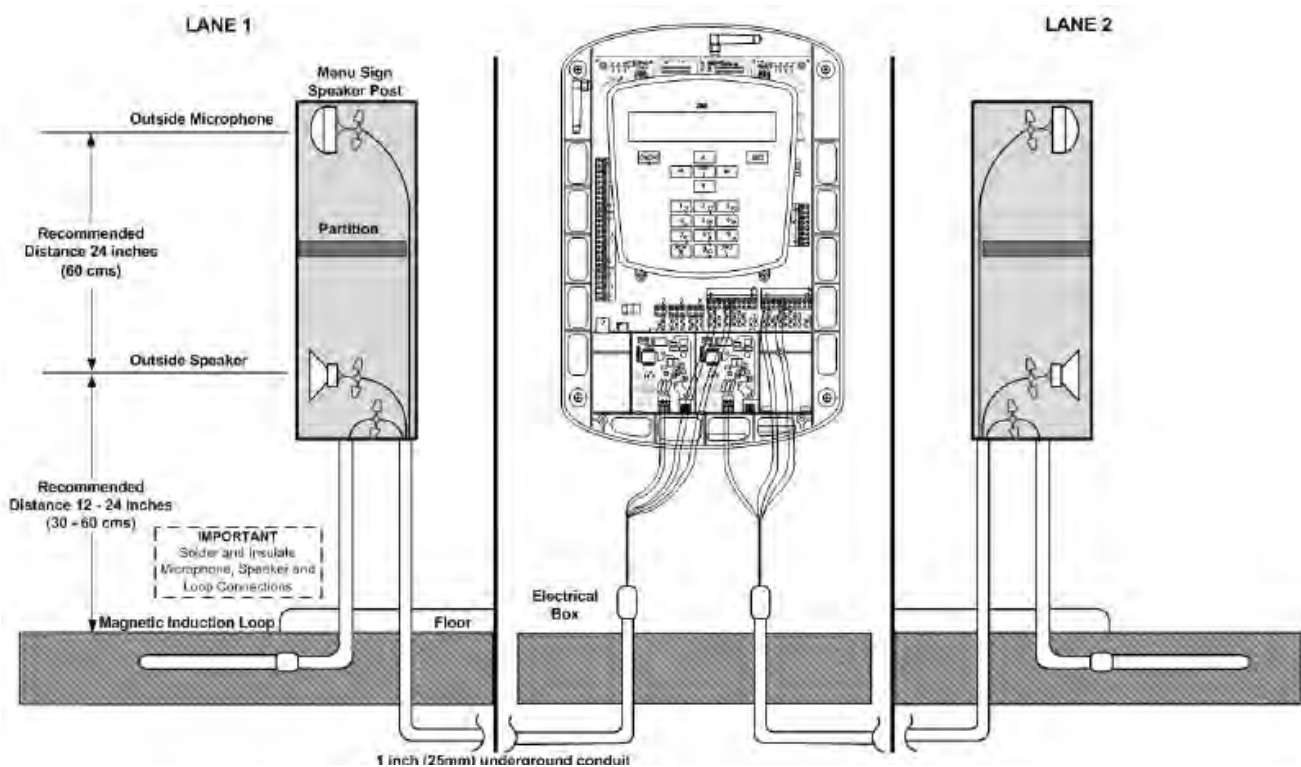

**Figure 14.**

Figure 15 shows the wiring configuration between a basestation and the components of a dual lane drive-thru. If the installation is for a single lane operation, refer to Lane1 wiring in the illustration above.

### **i** IMPORTANT NOTE

Vehicle Detector 1 (D1\_12V, D1\_GND and D1\_DET) must always be used for Lane 1 basestation operation and Vehicle Detector 2 (D2\_12V, D2\_GND and D2\_DET) must always be used for Lane 2 basestation.

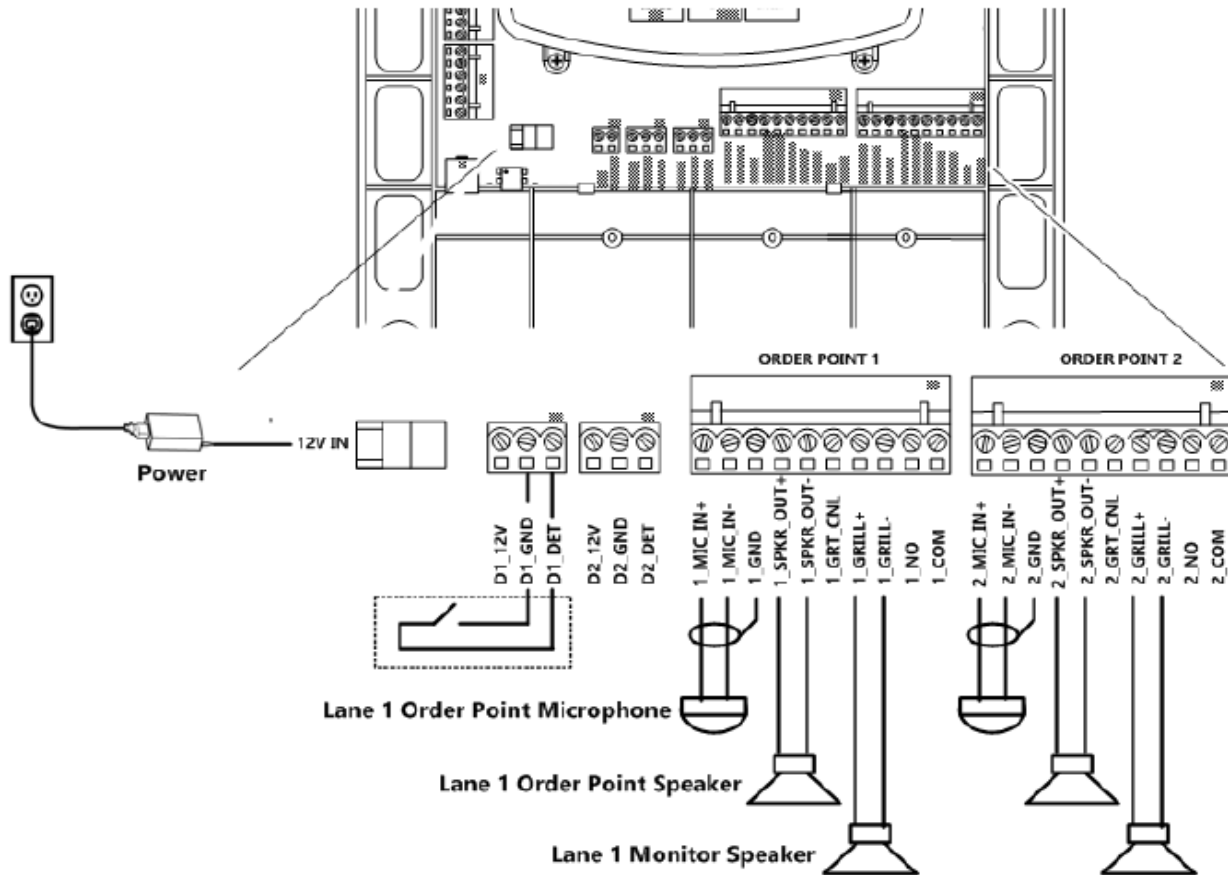

Figure 15.

## K. Auxiliary Detector Relays

You can use the basestation's vehicle detection circuits to operate an auxiliary relay for a number of convenient uses (typically an external greeter or timer module, but could also be used to operate a vehicle approach chime or other device that is independent of the intercom system). Virtually any device that can be activated by opening or closing a switch can be linked to vehicle detection.

The relay terminals are numbered according to the vehicle detector they are paired with. For example, R\_NC, R1\_NO, and R1\_COM are paired with Vehicle Detector 1.

There are several other sources from which to obtain the vehicle detector relay signals. They are:

1. The 1\_NO and 1\_COM from Lane1 connector and 2\_NO and 2\_COM from the Lane2 Connector.
2. The 16 logical GPIOs can be configured via the basestation's System Menu, to pair up with the vehicle detectors for Lane1 or Lane2.

## Short Circuit Example

Figure 16 shows a simple DC circuit (a light and DC power supply) being operated by the auxiliary relay. To make the light turn on when a vehicle is detected on Lane1, terminals R1\_COM and R1\_NO (normally open) would be used. To make the light turn off when a vehicle is detected Lane1, terminals R1\_COM and R1\_NC (normally closed) would be used.

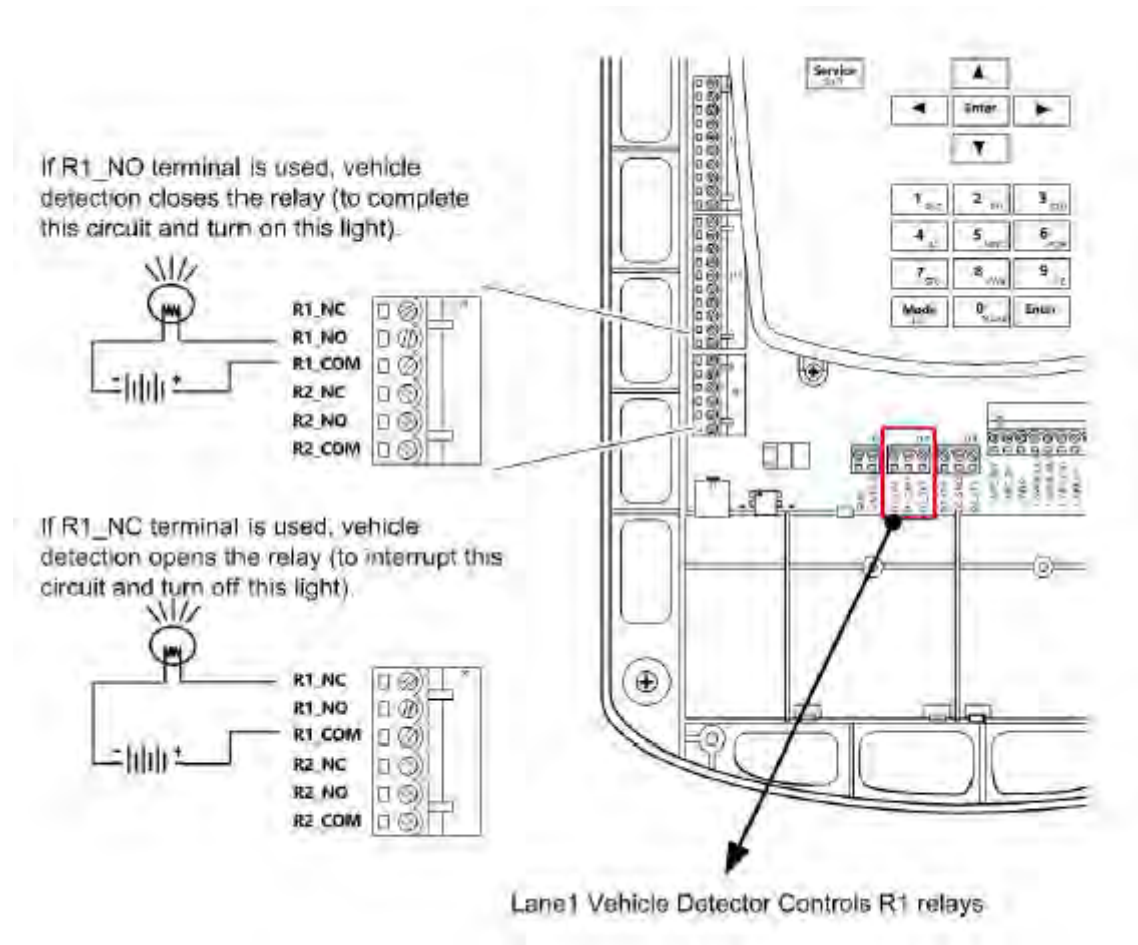
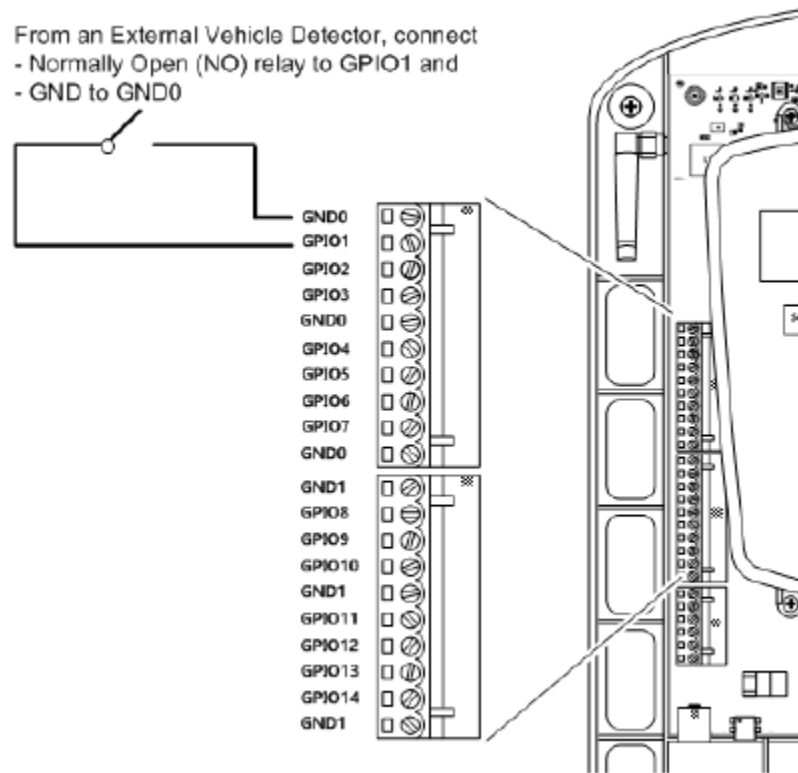

**Figure 16.**

## Vehicle Approach Monitor

Configure any of the 16 GPIOs to be used as a vehicle approach monitor. The relay closure signal to these GPIOs can be supplied by an external vehicle detector connected to an induction loop, in the drive-thru, which monitors an

approaching vehicle. A typical wiring is illustrated in Figure 17.



**Figure 17.**

**IMPORTANT NOTE**

GPIO15 and GPIO16 are located in the Lane1 and Lane2 Order Point Connectors.

## L. Installing Accessory Boards in the Basestation

Accessory boards include up to two vehicle detectors for a dual lane operation and a backup module. They must be installed into the base station according to the following procedures.

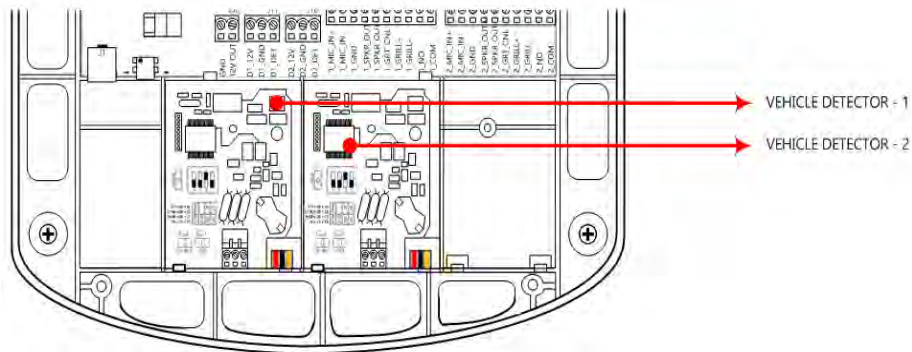

**Figure 18.**

## Vehicle Detectors

There are two available installation slots at the bottom of the base-station for vehicle detector boards, one for each lane of drive-thru operation. Once installed, each detector board must be configured for sensitivity, delay, and pulse/presence detection.

- Sensitivity—there are four available sensitivity settings: low, medium low, medium high, and high. Setting a high sensitivity increases vehicle detection but also increases the likelihood of false detection (e.g., unwanted detection of vehicles not in the drive-thru).
- Delay—you can enable a two second delay that waits until a vehicle has been detected for two seconds before the detection alert is triggered. Enabling the delay prevents the detection alert when cars drive over the detector without stopping to order.
- Presence/pulse setting—typical vehicle detectors detect the presence of a vehicle. They remain active for as long as a vehicle is in range of the detector; however, there are some types (e.g., air hoses) that only trigger when a vehicle drives over them with no further feedback to indicate whether the vehicle remains. The fourth dip switch must be set to the type of detector you have.

Perform the following procedure to install and configure a vehicle detector board:

- Ensure that the basestation is unplugged.
- Remove the basestation cover, see “Removing and Replacing the Cover” on page 16.
- Align the bottom of the vehicle detector board with the installation slot.
- Slide the top edge of the board between the back of the basestation and the two raised tabs.
- Install and gently tighten the screw.
- Carefully install the three wires between the vehicle detector board and the basestation board (see Figure 19). The left-to-right pin order is the same on both boards: the left pin on one corresponds to the left pin on the other.
- Configure the dip switches according to the table on the circuit board and your needs (see Figure 20).

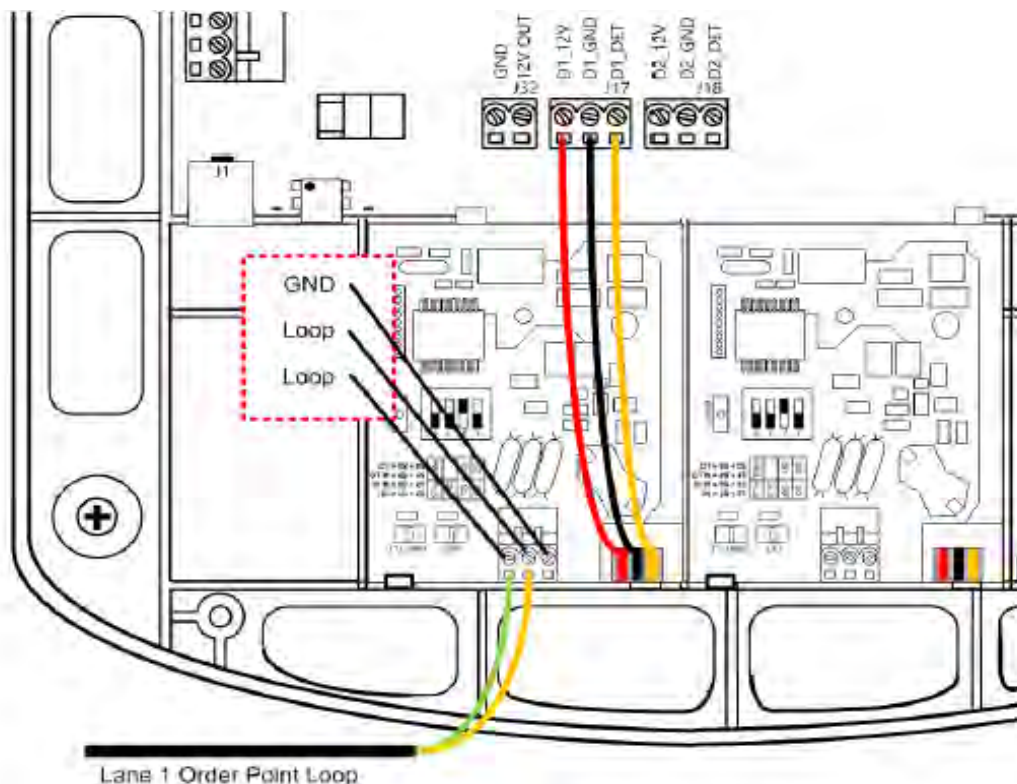
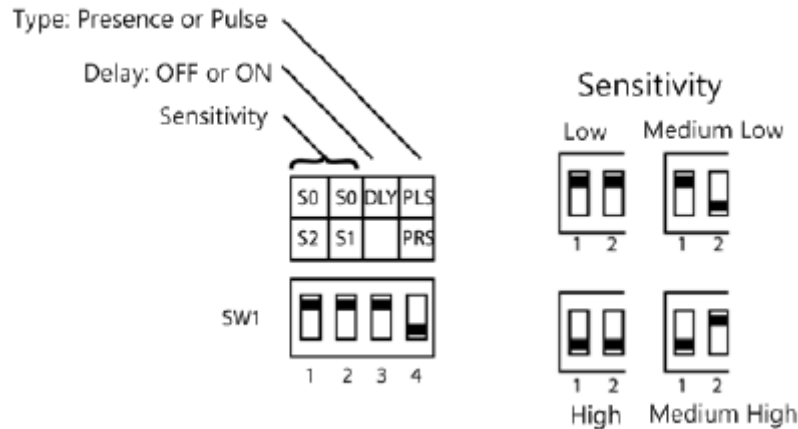

Figure 19.



- Adjust the sensitivity of vehicle detection by manipulating the top two dip switches.
- Enable or disable a two second detection delay by manipulating the third switch
- Choose presence or pulse detection by manipulating the fourth switch.



**Figure 20.**

## Vehicle Detector LED

There are two small LEDs on the vehicle detector that can be in one of three states when powered and operating:

- Steady green—indicates that power is applied and no vehicle is currently detected.
- Flashing green, single flash every 1.5 seconds—indicates an open loop fault (a wire is disconnected or severed).
- Flashing green, double flash every 1.5 seconds—indicates a shorted loop fault (the loop wires are making unwanted contact at some point before they reach the loop detector).
- Steady red—indicates that power is applied and a vehicle is currently detected.

### **IMPORTANT NOTE**

The vehicle detector fails closed; therefore if there is a fault, the system assumes that there is a vehicle present.

## Greeter Alert Trigger Inputs

The Greeter functionality is built into the G5 Basestation Model G5B1. In addition to playing back a Greet message to the customer at the Order Point and/or playing a Reminder message at a scheduled time of day, the user can also program the system to playback an Alert message whenever an external event occurs, such as Opening the Back Door or Opening the Refrigerator.

The installer can configure any of the 16 GPIOs on the G5 Basestation Model G5B1 as ALERT Message Trigger Inputs. For example, if you chose to wire the back door sensor to GPIO1 and GND, any time these two pins are shorted, the ALERT message assigned to this input (such as Back Door Open) will play on each headset configured to play the ALERT Message. See Figure 21 for an example.

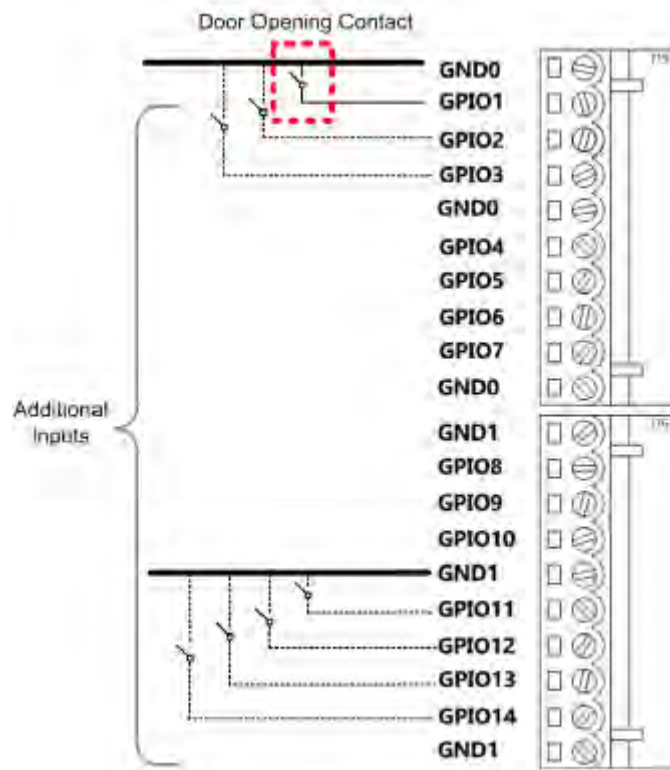

Figure 21.

## M. Power Up

After installation is complete, you can power up the system by plugging in the basestation transformer.

## Run Mode Menu

When the system is powered up and functioning normally, the Run mode menu appears on the display. Figure 22 shows the Run mode menu.

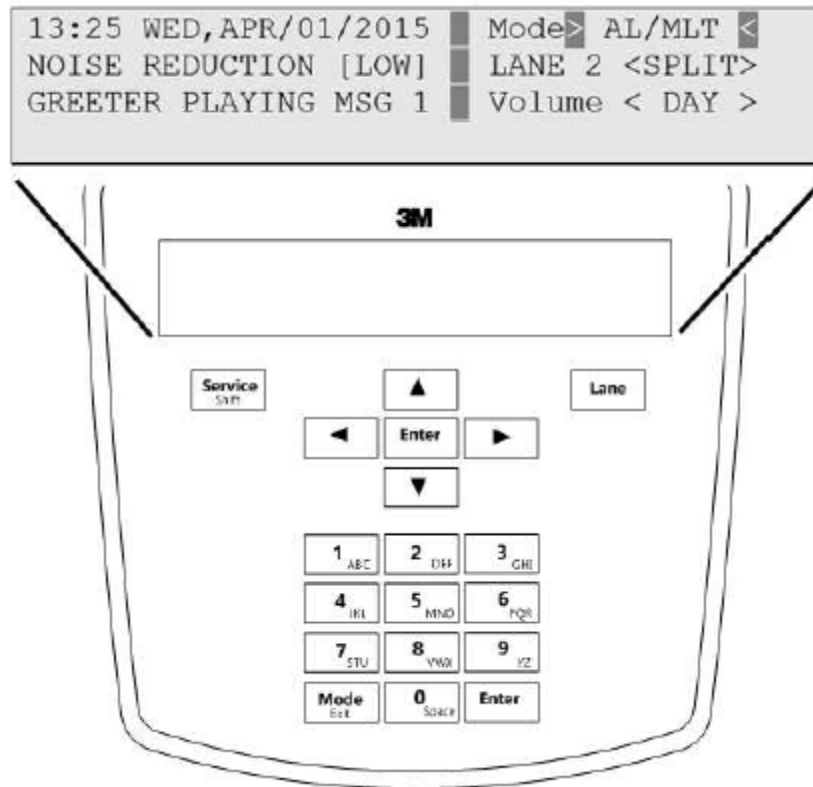

Figure 22.

## Navigating in the Basestation in Run Mode

To navigate the base station in Run mode you only need to use Enter, Mode, and the directional arrow buttons. The remaining buttons function only in manager or installer configuration modes.

### **i** IMPORTANT NOTE

#### **Special Short Cut Keys**

While on the Run Mode and no fields are selected for editing, the left and right buttons act as short cut keys to two frequently accessed configuration screens. Pressing, the right button – Launches the Greeter Message Activation screen. Pressing the left button – Launches the Add New Headsets screen.

## 3. Configuration

### A. Enter Configuration Mode

Configuration mode is a passcode-protected area that contains most of the configuration options for the basestation system. Using the access provided for users it is possible to set up all of the functionality of the system.

To enter the configuration mode:

- From the Run mode menu.
- Enter your user passcode.
- Press **Mode**. The display will show the user name and ID number (e.g., User1 ID = 1).
- Press **Mode** again. The display will show the **Main Menu** with options to select **1 System Menu** or **2 Greeter Menu**.

```
08:35 SUN, DEC/25/2016 | Mode > AL/MLT <
Noise Reduction [MED] | Single Lane
Greeter | Volume < DAY >
USER MODE, ID = 1
```

```
                :MAIN MENU:
1>System Menu<
2 Greeter Menu
```

Figure 23.

#### IMPORTANT NOTE

There are two levels of passcode: installers and users. Using a user's passcode permits you into all system menu items except those reserved for installers.

The default user password is 1234.

The default installer password is 12345.

### B. Navigating the Basestation Display

Once you are in the configuration mode, you can use the buttons on the basestation display to update all configuration parameters.

## Interpreting Display Information

Depending upon what you are doing, or what you can do, text on the display screen is handled according to the following conventions:

<b>Static or Informational</b>	Static, informational, or noneditable text has no markings on it.
<b>&lt;Editable, not selected&gt;</b>	Editable items that are not currently-selected appear inside of outwardly-pointing pointers.
<b>&gt;Editable, Selected&lt;</b>	Editable items that are currently selected appear inside if inwardly-pointing pointers.
<b>Editable, in Edit Mode</b>	Editable items that are currently being edited have arrows pointing inwardly.
<b>[Variable, not Editable]</b>	Variable items that cannot be edited appear inside of square brackets. In some cases the item is editable, but only from a different location in the menu.
<b>{ information }</b>	An on-screen explanation of a key point or reminder appears within curved brackets.

## Buttons

Following is a brief description of the buttons on the display and their functions.

<b>Directional arrow buttons</b>	You can use these buttons to scroll around when navigating the menus. When you are editing information, the up and right arrows scroll “up” (increment) and the down and left arrows scroll “down” (decrement) list of values.
<b>Number/letter (0 – 9) buttons</b>	You can use these buttons to specify exact numbers or letters in fields that permit them. Each time you press button, the result changes to the next available number or letter. For instance, pressing the 7 button three times creates a letter “t” (7-s-t). See <b>Service</b> button below for creating upper-case letters.
<b>Mode (Exit) button</b>	In run mode, you must press the <b>Mode</b> key after entering your passcode to enter user or installer level security. In user and installation service modes, use the <b>Mode</b> button to exit from a current field that you are editing without saving any changes or to go upward (backward) in the configuration menus.
<b>Enter (Select) buttons (both buttons perform the exact same functions)</b>	Use the <b>Enter</b> button to execute the current selection: Pressing <b>Enter</b> on a menu opens the menu and shows you its submenu items. Pressing <b>Enter</b> on an editable field switches you to edit mode so you can change the value in the field using the arrows and number/letter buttons where applicable. Pressing <b>Enter</b> while in edit mode saves the changes you have made and exits edit mode.
<b>Service (Shift) button</b>	Use the <b>Service</b> button to access upper-case letters or to initiate a service call to 3M or as a confirmation in some items. Pressing and holding the <b>Service</b> button while editing a field that permits alphabet letter entry (e.g., store address) shifts the letter to upper case. In run mode, press the <b>Service</b> button. The base station will go to a <b>Service</b> screen used for installation and troubleshooting.
<b>Lane button</b>	Use the <b>Lane</b> button to switch between Lane1 and Lane2. The Display Screen will switch appropriately and display only those configuration settings that are available for that Lane. This applies to the Run Screen and all Menu screens.

The directional arrows can be used for scrolling from one menu item to another or to scroll through available choices when editing fields.

## C. Finding the MAC Address of the G5 Basestation

To find the MAC address of the G5 Basestation.

- Enter the configuration mode, see “Enter Configuration Mode” on page 28, and choose **1 System Menu**.
- Select **16 Network Setup**.
- Note the 6 pairs of alpha-numeric characters (enclosed in square brackets), against the **MAC Address** field.

Note that your G5 Basestation may contain a different set of characters than the one illustrated below:

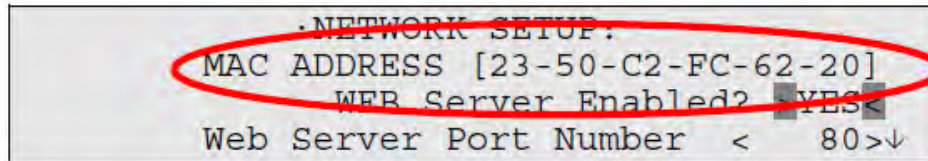

Figure 24.

## D. Configuring with a Computer

All of the procedures in this chapter assume that you are using the display to configure your basestation(s). However, the basestation can function as a web server, which means it can be configured using a PC. The web server functionality is enabled on the basestation by default. To set up web-server functionality:

1. Connect the base station:
  - a. **Peer-to-Peer** – a direct connection between the basestation and the PC using a crossover cable.
  - b. **Private network** – a connection between the basestation and a router, switch or hub using an Ethernet cable. The PC is somewhere on the same network.
2. Enter the configuration mode, see “Enter Configuration Mode” on page 28, and choose **1 System Menu**.
3. Select **16 Network Setup**.
4. Change the values for **IP address**, **subnet mask**, and **default gateway**, according to the table below.
5. Cycle the power to the basestation.
6. Enter the configuration mode.
7. Select **16 Network Setup**.
8. Verify the values for **web server enabled** is **Yes**, or else change this value to **Yes**.
9. Cycle the power to the basestation.

Setting		If Peer-to-Peer	If Private Network
<b>IP Address</b>	Base Station	192.168.99.2	192.168.0.110 (or another unused address in the same address space as the DHCP address)
	PC	192.168.99.1	DHCP
<b>Subnet Mask</b>	Base Station	255.255.255.0	255.255.255.0
	PC	255.255.255.0	No requirement
<b>Default Gateway</b>	Base Station	192.168.99.1	192.168.0.1 (or the switch, router, or hub address)
	PC	Leave blank	192.168.0.1 (or the switch, router, or hub address)

## E. Logging into the Base Station with a PC

Once the base station is connected and configured you can log into it from any other computer on the network and operate the station as you would from the local interface.

To log into the base station:

1. Using a web browser, type in the IP address of the base station in the browser's Address bar, then press **Enter**.
2. Type in your user name and password, then press **Enter**.
  - a. The default user name is "User1"; the default password is "1234".

## F. Switching Between Lane1 and Lane2

At any time, while configuring the basestation or while on the Run Screen, you can switch the display screen to show Lane1 or Lane2 settings by pressing the **Lane** button on the keypad.

Here are some display screens that indicate a successful switch.

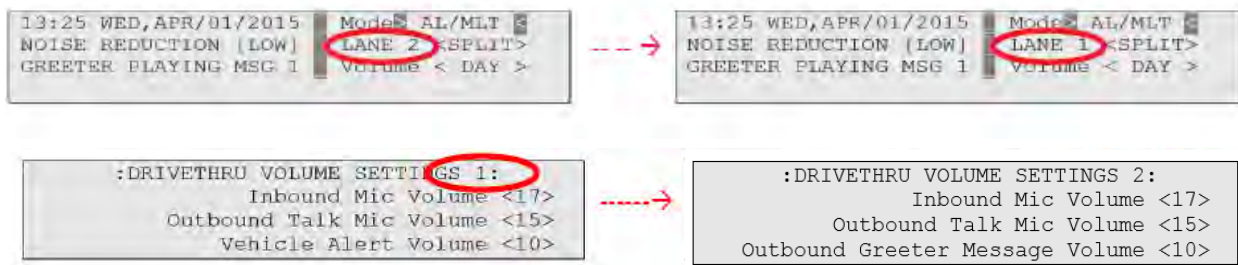

Display Screens that are not effected by Lane change do not have the Lane number listed on the screen's header. For example:



Figure 25.

## G. Menu Options for Lane1 and Lane2

There are very few menu options that are available on Lane1 settings and not on Lane2; and vice versa. The table below provides a high level view of the menu structure for Lanes 1 and 2.

Menu	Available on Lane1	Available on Lane2
<b>System Menu</b>		
- 01 Drivethru Volume		
- Inbound Mic Volume	Yes	Yes
- Outbound Talk Volume	Yes	Yes
- Vehicle Alert Volume	Yes	No
- Outbound Greeter Message Volume	Yes	Yes
- External Audio-Input Volume	Yes	Yes
- Mic Preamp Gain (Installer Only!)	Yes	Yes
- 02 Monitor Volume		
- Inbound Listen: Volume	Yes	Yes
- Outbound Talk: Volume Enable	Yes	Yes
- Vehicle Present: Volume Enable	Yes	Yes
- Vehicle Approach: Volume Enable	Yes	Yes
- PAGE Messages: Volume Enable	Yes	Yes
- Ext. Audio-In: Volume Enable	Yes	Yes
- Greeter Messages: Volume Enable	Yes	Yes
- Lane Monitor Outputs	No	Yes
- 03 Night Volume		
- Day Outbound Talk Volume Setting Is	Yes	Yes
- Reduce DriveThru Volume At Night By	Yes	Yes
- 04 Registration	Yes	No
- 05 Noise Reduction		
- Inbound Mic Noise Reduction Level	Yes	Yes
- Acoustic Echo Canceller	Yes	Yes
- 06 Set Time & Date		
- Time	Yes	No
- Date	Yes	No
- TimeZone	Yes	No
- 07 Global Settings		
- Text & Audio Prompts Language	Yes	No
- DriveThru Audio Duplex Mode	Yes	No
- PAGE Channel Heard By Order Taker	Yes	No
- "Store is Now Closed" Prompt	Yes	No
- Order Point Prompts in English?	Yes	No
- Order Point Prompts in Spanish?	Yes	No
- Order Point Prompts in French?	Yes	No
- Order Point Prompts in German?	Yes	No
- Order Takers in CROSS Lane Mode	Yes	No



Menu	Available on Lane1	Available on Lane2
- PAGE Messages Can Cross Lanes?	Yes	No
- Order Point TALK With No Vehicle	Yes	No
- “Pull Ahead” Prompt (Tandem ONLY)	No	Yes
- Vehicle Detector #1 Type	Yes	No
- Vehicle Detector #2 Type	No	Yes
- Vehicle Detector #1 Minimum	Yes	No
- Vehicle Detector #2 Minimum	No	Yes
- Auto Un-Mute HS Mic in Hfree Mode	Yes	No
- External Audio-In Routing Mode	Yes	No
- Ext. Audio-In Gate Threshold Level	Yes	No
- Mute External Audio-In When Busy	Yes	No
- Kitchen Noise Reduction	Yes	No
- Haptic Alerts on Headsets	Yes	No
- Blue LED Alerts on Headsets	Yes	No
- 08 Headset Setup	Yes	No
- 09 O.T. Modes Setup	Yes	No
- 10 Site Scheduling	Yes	No
- 11 Site Information	Yes	No
- 12 Digital IO Setup	Yes	No
- 13 Change Passwords	Yes	No
- 14 Installer Setup	Yes	No
- 15 Factory Setup	Yes	No
- 16 Network Settings	Yes	No
- 17 Reboot System	Yes	No
- 18 Revision Levels	Yes	No
Greeter Menu		

## H. Change Basic Volume Settings

### IMPORTANT NOTE

All volume settings should be adjusted during normal or peak business hours. Adjusting them during slow times will likely produce volume settings that are too low.

### IMPORTANT NOTE

Inbound and outbound are always defined from the perspective of the headset.

## Inbound Microphone Volume

Changing the inbound microphone volume affects the sound volume coming from the customer order point microphone.

To turn up or down the inbound microphone:

- Enter the configuration mode, see “Enter Configuration Mode” on page 28, and choose **1 System Menu**.
- Select a new value for **01 Drivethru Volume > Inbound Mic volume**. The range is 0 (silent) to 20 (max).

## Outbound Talk Volume

Changing the outbound talk volume affects the volume of the speaker at the customer order point.

### IMPORTANT NOTE

To avoid feedback, set the outbound talk volume as low as possible.

To change the outbound talk volume:

- Enter the configuration mode, see “Enter Configuration Mode” on page 28, and choose **1 System Menu**.
- Select a new value for **01 Drivethru Volume > Outbound Talk Volume**. The range is 0 (silent) to 20 (max).

## Vehicle Alert Volume

Changing the vehicle alert volume affects the volume of the vehicle alert signal on the headsets.

To change the vehicle alert volume:

- Enter the configuration mode, see “Enter Configuration Mode” on page 28, and choose **1 System Menu**.
- Select a new value for **01 Drivethru Volume > Vehicle Alert Volume**. The range is 0 (silent) to 20 (maximum).

## Outbound Greeter Message Volume

Changing the outbound greeter message volume affects the sound volume of the custom greeting messages and the system internal greetings (“Store Closed” and “Pull Forward”).

To turn up or down the greeter message volume:

- Enter the configuration mode, see “Enter Configuration Mode” on page 28, and choose **1 System Menu**.
- Select a new value for **01 Drivethru Volume > Outbound Greeter Message Volume**. The range is 0 (silent) to 20 (max).

## Change the Monitor Volume

The monitor is an additional speaker that can be used to monitor drive thru communication without a headset, typically in the kitchen. If the monitor has a volume control built into it, you can use it to control the overall volume level of the speaker. To be more specific about which elements you want to control, follow the instructions in the following sections.

### Inbound Listen

Changing the inbound listen volume affects how loudly the monitor plays the inbound (customer order point) communication. You can also disable the monitor playing inbound sounds.

To change the inbound listen monitoring settings:

- Enter the configuration mode, see “Enter Configuration Mode” on page 28, and choose **1 System Menu**.
- Select **02 Monitor Volume**.
- To enable or disable the monitor playing the inbound sounds, change the value for **Inbound Listen: Enable** to **ON** or **OFF**.
- To change the volume level, select a new value for **Inbound Listen: Volume**. The range is 0 (silent) to 20 (maximum).

### Outbound Talk

Changing the outbound talk volume affects how loudly the monitor plays the outbound (order taker) communication. You can also disable the monitor playing outbound talk.

## IMPORTANT NOTE

To avoid feedback and echo, set the outbound talk volume as low as possible.

To change the outbound talk monitoring settings:

- Enter the configuration mode, see “Enter Configuration Mode” on page 28, and choose **1 System Menu**.
- Select **02 Monitor Volume**.
- To enable or disable the monitor playing the outbound talk, change the value for **Outbound Talk: Enable** to **ON** or **OFF**.
- To change the volume level, select a new value for **Outbound Talk: Volume**. The range is 0 (silent) to 20 (maximum).

## Vehicle Present

Changing the vehicle present volume affects how loudly the monitor plays the vehicle present tone. You can also disable the monitor playing the vehicle present tone.

To change the vehicle present monitoring settings:

- Enter the configuration mode, see “Enter Configuration Mode” on page 28, and choose **1 System Menu**.
- Select **02 Monitor Volume**.
- To enable or disable the monitor playing the vehicle present tone, change the value for **Vehicle Present: Enable** to **ON** or **OFF**.
- To change the volume level, select a new value for **Vehicle Present: Volume**. The range is 0 (silent) to 20 (maximum).

## Vehicle Approach

Some sites are equipped with a vehicle approach detector, which alerts you when a vehicle enters the parking lot or drive through approach lane. If your site is equipped with the detector, you can change the volume at which the tone is played on the monitor. Also, if you do not wish to hear the tone, you can disable it.

To change the vehicle approach monitoring settings:

- Enter the configuration mode, see “Enter Configuration Mode” on page 28, and choose **1 System Menu**.
- Select **02 Monitor Volume**.
- To enable or disable the monitor from playing the vehicle approach tone, change the value for **Vehicle Approach: Enable** to **ON** or **OFF**.
- To change the volume level, select a new value for **Vehicle Approach: Volume**. The range is 0 (silent) to 20 (maximum).

## Page Messages

Paging is headset-to-headset communications. Changing the page message volume affects how loudly the monitor plays internal paging messages. You can also disable the monitor playing internal paging messages.

## IMPORTANT NOTE

To avoid feedback and echo, set the volume as low as possible.

To change the page message volume monitoring settings:

- Enter the user service mode, see “Enter Configuration Mode” on page 28, and choose **1 System Menu**.
- Select **02 Monitor Volume**.
- To enable or disable the monitor playing internal paging messages, change the value for **PAGE Messages: Enable** to **ON** or **OFF**.

- To change the volume level, select a new value for **PAGE Messages: Volume**. The range is 0 (silent) to 20 (maximum).

## Greeter Messages

Changing the greeter message volume affects how loudly the monitor plays the greeter messages. You can also disable the monitor playing the greeter messages.

To change the greeter message volume monitoring settings:

- Enter the configuration mode, see “Enter Configuration Mode” on page 28, and choose **1 System Menu**.
- Select **02 Monitor Volume**.
- To enable or disable the monitor playing greeter messages, change the value for **Greeter Messages: Enable** to **ON** or **OFF**.
- To change the volume level, select a new value for **Greeter Messages: Volume**. The range is 0 (silent) to 20 (maximum).

## Monitoring Audio Separately for the Two Lanes

The “Lane Monitor Outputs” option only appears when the basestation is operating in a Dual Lane. It has two choices – “Mixed” or “Separate”.

In **Mixed** mode, all Monitor audio from both lanes 1 and 2, are played on the single Speaker.

In **Separate** mode, if you have hooked up two separate speakers for the two lanes, then traffic on Lane1 is played on Speaker1; traffic from lane2 is played on speaker2.

## Change the Night Volume

You can assign a standard reduction in the volume level of the customer order point speaker for night hours when lower volume is typically required. With the night volume set, the system automatically adjusts the volume during night hours, then back to normal during the day.

To change the night volume setting:

- Enter the configuration mode, see “Enter Configuration Mode” on page 28, and choose **1 System Menu**.
- Select a new value for **03 Night Volume > Reduce DriveThru Volume At Night By**. The range is 0 (No reduction) to the current day volume level (silent).

### **IMPORTANT NOTE**

Night Volume is never higher than Day Volume.

Night volume reduction is a subtracted value, not the resulting level; therefore, if it is the same as the day volume level, the speaker will turn off at night.

You cannot change the day outbound talk volume on this screen, only the reduction amount identified above.

## Registering Headsets

Each headset must be registered to a basestation before it can be used.

XT-1 headsets have a single serial number. This number is imprinted on the headset.

G5 headsets have 2 serial numbers - one for the G5 Control Pod and the other for the G5 Carrier. The G5 Control Pod serial number is the primary tracking number for the G5 headset and this is the serial number that gets registered on the basestation. Once registered, it should not need to be registered again unless it is intentionally removed.

## Add Headsets

The procedure below applies to both G5 and XT-1 headsets. Each headset has a unique serial number. This number is broadcast to the basestation whenever the headset signs on.

### IMPORTANT NOTE

One headset should not be registered to more than one active basestation at any given site, whether or not the bases are interconnected.

To register a headset:

- Enter the base station configuration mode, see “Enter Configuration Mode” on page 28, and choose **1 System Menu**.
- Select **04 Registration > 1 Add New Headsets**.
- Power on the headset when prompted.  
Or in the case of a G5 headset, insert the battery to automatically power on the headset.
- Wait up to two minutes for **{Headset xxxxxx Has Been Registered!}** to appear at the bottom of the display.
- Repeat the steps above for additional headsets.
- Press **Mode** when finished.

### IMPORTANT NOTE

Alternatively, you may use the Special Short Cut Keys. While on the Run Mode and no fields are selected for editing, the left, and right buttons act as short cut keys to two frequently accessed configuration screens. Press the left arrow – Launches the Add New Headsets screen.

## Remove Headsets

Perform the following steps to un-register a lost, destroyed, or otherwise removed headset from the system, including a headset that is sent back to 3M for repair. The headset would have to be registered again at a later date.

- Enter the base station configuration mode, see “Enter Configuration Mode” on page 28, and choose **1 System Menu**.
- Select **04 Registration > 2 Remove Headsets**.
- Scroll to the number of the headset you want to un-register.
- Press **Enter**.

### IMPORTANT NOTE

If you do not know or have access to the number of the headset to be unregistered, identify the headsets that you want to remain in service and un-register any that remain on the list.

Another method to identify the headset’s serial number without having to disassemble the headset is through the Basestation’s Headset Setup Menu.

- Enter the base station configuration mode, see “Enter Configuration Mode” on page 28, and choose **1 System Menu**.

- Select **08 Headset Setup**.
- Pay attention to the Serial Number displayed to the right of Currently Editing Headset field.
- Conduct a Page with the operational XT-1 or G5 headset on hand.
- The Headset Selection field will jump to the headset that is currently paging, which is the headset in your hand.
- Read the serial number off this field.

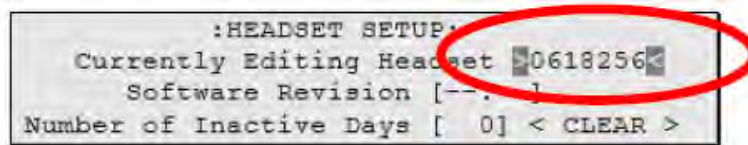

**Figure 26.**

### **(i) IMPORTANT NOTE**

This field will only display the last 7 digits of the Headset's (or G5 Control Pod's) serial number.

### **List All Headsets**

To see a list of the registered headsets:

- Enter the base station configuration mode, see “Enter Configuration Mode” on page 28, and choose **1 System Menu**.
- Select **04 Registration > 3 List All Headsets**.

### **Resetting Inactive Days**

For any headset, you can manually reset its number of inactive days to zero.

To reset the inactive days:

- Enter the base station configuration mode, see “Enter Configuration Mode” on page 28, and choose **1 System Menu**.
- Navigate to **08 Headset Setup > Currently Editing Headset**.
- Press < or > if necessary to scroll to the headset ID number for the headset you want to reset.
- Select **<CLEAR>**.

### **Checking Headset Software Revision**

To check the software revision number for a headset:

- Enter the base station configuration mode, see “Enter Configuration Mode” on page 28, and choose **1 System Menu**.
- Navigate to **08 Headset Setup > Currently Editing Headset**.
- Press < or > if necessary to scroll through the headsets. The software version appears below the headset ID number.

## Identifying Headset Serial Number

To identify the last 7 digits of a XT-1 headset or G5 Control Pod) registered to this basestation:

- Enter the base station configuration mode, see “Enter Configuration Mode” on page 28, and choose **1 System Menu**.
- Navigate to **08 Headset Setup**.
- Pay attention to the Serial Number displayed in the Headset Selection Field to the right of **Currently Editing Headset**.
- Conduct a PAGE with the operational XT-1 or G5 Headset on hand.
- The Headset Selection Field will jump to the headset serial number that is currently paging.
- Read the serial number off this field.

## I. Change Noise Reduction Level

There are several ways to improve the sound quality at the headset using the following settings.

### Inbound Microphone Noise Reduction Level

The inbound microphone noise reduction level setting reduces background noise to make it easier to hear speech at the customer order point.

Perform the following steps to increase or decrease the noise reduction level.

- Enter the base station configuration mode, see “Enter Configuration Mode” on page 28, and choose **1 System Menu**.
- Make a new selection for **05 Noise Reduction > Inbound Mic Noise Reduction Level**. Options are **Off, Min, Low, Med, Hi, and Max**. You may need to experiment for a setting that works best for your ambient noise environment.

### Acoustic Echo Canceller

Perform the following procedure if there is a delayed repetition (echo) of the outbound sound:

- Enter the base station configuration mode, see “Enter Configuration Mode” on page 28, and choose **1 System Menu**.
- Make a new selection for **05 Noise Reduction > Acoustic Echo Canceller**. Options are **Min, Low, Med, and Max**. You may need to experiment for a setting that works best for your ambient noise environment and staff.

## J. Set System Date and Time

Perform the following procedure to set the system time and date.

- Enter the base station configuration mode, see “Enter Configuration Mode” on page 28, and choose **1 System Menu**.
- Change the date and time values for **06 Set Time & Date** in the **Time** and **Date** fields as required. Use the arrows to scroll from one field to the next and type new values over the existing data in the formats shown in parentheses:
  - HH = Hours (01 to 24, e.g., 6:00 pm is 18)
  - MM = Minutes (01 to 60)
  - SS = Seconds (01 to 60)
  - MMM = Month (Jan, Feb, Mar, Apr, May, Jun, Jul, Aug, Sep, Oct, Nov, or Dec)
  - DD = day (01 to 31)
  - Year = Last two digits of the year (00 to 99, 20 is fixed and cannot be changed)

## K. Change Global Settings

Global settings are an assortment of options that you must choose based upon the basic configuration of your system.

## Text and Audio Prompts Language

You can choose between English, Spanish, German, and French language for all text and audio prompts, which is essentially all of the factory prerecorded information coming from the base station and all of the printed text on the display.

### IMPORTANT NOTE

Changing the text and audio prompt language will also change the language of the headset messages.

Perform the following procedure to change the text and audio prompts:

- Enter the base station configuration mode, see “Enter Configuration Mode” on page 28, and choose **1 System Menu**.
- Change the value for **07 Global Settings > Text & Audio Prompts Language** to **English, Español, Deutsch,** or **Francais**.

## Drive Thru Audio Duplex Mode

The system can function using half duplex or full duplex modes. Choosing between the two modes is based upon the desired operation.

### IMPORTANT NOTE

In half duplex installations, all latching order taking modes and hands free mode are disabled.

Perform the following procedure to change the drive through audio mode:

- Enter the base station configuration mode, see “Enter Configuration Mode” on page 28, and choose **1 System Menu**.
- Change the value for **07 Global Settings > DriveThru Audio Duplex Mode** to **Full** or **Half**.
  - In half-duplex systems, when the order taker is speaking, it is impossible to hear any speech coming from the customer order point.
  - In full-duplex systems, the order taker can speak and hear speech coming from the customer order point at the same time.

## Page Channel Heard by Order Taker

You can enable or disable the order taker from being able to hear any paging while speaking to a customer over the customer order point. This may prevent interference with the order taking process.

Perform the following procedure to enable or disable the order taker hearing pages while talking:

- Enter the base station configuration mode, see “Enter Configuration Mode” on page 28, and choose **1 System Menu**.
- **Select 07 Global Settings.**
- To enable or disable the monitor playing the outbound talk, change the value for **PAGE Channel Heard by Order Taker:** to **NO** or **YES**.

## Store is Now Closed Prompt

Perform the following procedure to enable or disable the automatic store closed prompt to let customers know in your absence that the store is closed:

### IMPORTANT NOTE

Make sure that you disable the automatic store closed prompt in stores that are open 24 hours.



- Enter the base station configuration mode, see “Enter Configuration Mode” on page 28, and choose **1 System Menu**.
- Change the value for **07 Global Settings > ”Store is Now Closed” Prompt?** to **Yes** or **No**.

## Pull Ahead Prompt

You can let customers know to pull ahead when they are at order point #2 in a tandem drive-thru when:

- it is out-of-service.
- no car is present at order point #1.

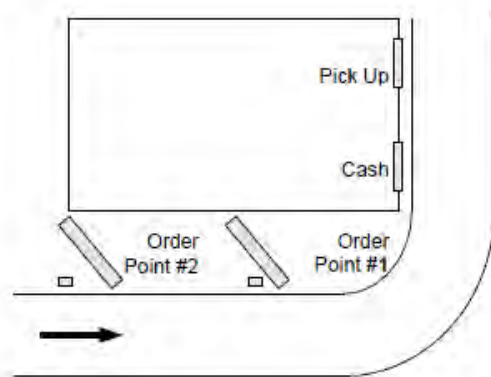

**Figure 27.**

This option is available on Lane2 settings only. Perform the following procedure to enable or disable the automatic pull ahead for Order Point #2:

- Enter the base station user service mode, see “Enter Configuration Mode” on page 28, and choose **1 System Menu**.
- Press the **Lane** button.
- Change the value for **07 Global Settings > ”Pull Ahead” Prompt (Tandem Only)?** to **Yes** or **No**.

## Customer Order Point Prompt Language

Perform the following procedure to select the language(s) of the store closed and pull ahead prompts. The prompts can be spoken in English, Spanish, French, German, or repeated in multiple languages:

- Enter the base station configuration mode, see “Enter Configuration Mode” on page 28, and choose **1 System Menu**.
- Change the value for **07 Global Settings > Order Point Prompts in English?** to **Yes** or **No**.
- Press **Enter** to implement the change or press **Mode** to abandon the change and leave the option at its previous setting.
- Change the value for **07 Global Settings > Order Point Prompts in Spanish?** to **Yes** or **No**.
- Press **Enter** to implement the change or press **Mode** to abandon the change and leave the option at its previous setting.
- Change the value for **07 Global Settings > Order Point Prompts in French?** to **Yes** or **No**.
- Press **Enter** to implement the change or press **Mode** to abandon the change and leave the option at its previous setting.
- Change the value for **07 Global Settings > Order Point Prompts in German?** to **Yes** or **No**.

## Order Takers and Page Messages in Cross Lane Mode

In systems with two customer order points, in cross lane mode, you must specify the number of order takers you will be using to make sure that non-order takers can hear orders being taken on one or both lanes. Similarly, you must specify whether you want page messages to be heard by all headsets or only within each lane.

Perform the following procedure to specify the number of order takers in cross lane mode.

- Enter the base station configuration mode, see “Enter Configuration Mode” on page 28, and choose **1 System Menu**.
- Change the value for **07 Global Settings > Order Takers in CROSS Lane Mode?** to **1** or **2**.
  - If you select 1, non-order takers will hear the orders from lanes 1 and 2.
  - If you select 2, non-order takers will hear only the orders on the lane for which the headset is configured.

Perform the following procedure to enable or disable paging to be heard by operators on both lanes.

- Enter the base station configuration mode, see “Enter Configuration Mode” on page 28, and choose **1 System Menu**.
- Change the value for **07 Global Settings > PAGE Messages Can Cross Lanes?** to **YES** or **NO**.

## Order Point TALK with No Vehicle

Perform the following procedure to permit or prevent the order taker to talk to the order point when no vehicle is detected.

- Enter the base station user service mode, see “Enter Configuration Mode” on page 28, and choose **1 System Menu**.
- Change the value for **07 Global Settings > Order Point TALK With No Vehicle?** to **Yes** or **No**.

## Detector Type

Because there are two basic types of vehicle detector, pulse and presence, you must specify which type you have in the base station.

- Enter the base station configuration mode, see “Enter Configuration Mode” on page 28, and choose **1 System Menu**.
- Change the value for **07 Global Settings > Vehicle Detector#1** to **Presence** or **Pulse**.

### IMPORTANT NOTE

Press the **Lane** button to configure Detector#2 on Lane2.

- For presence type detectors, specify a value for **Vehicle Detector #X Minimum (Seconds)**. Setting a higher number will increase the customer’s wait time, but decrease false detections that could be caused by cars driving over the detector without stopping.

### IMPORTANT NOTE

When the pulse setting is used, each call must be ended by pressing the page button on the headset.

If you are using a vehicle detector board, the presence or pulse setting should match the dip switch setting on the board.

If the vehicle detector is set to delay (via its own dip switches) and you set a delay in the base station, the delays are additive: you could end up with a longer than expected total delay.

## L. Haptics “Vibration” Alerts and Blue LED Alerts on Headsets

These options allow you to enable the G5 headset to:

- Gently vibrate and/or
- Flash a Blue LED (at the tip of the mic boom)

when a vehicle is detected at the Order Point. These options are, by default, set to **YES**.

This option only applies to G5 headsets. If you currently have no G5 headsets and only XT-1 headsets, then enabling or disabling this option will not affect the normal functioning of the XT-1 headset.

## Haptics “Vibration” Alerts on Headsets

Perform the following procedure to enable or disable the Haptics “Vibration” Alerts on the Headset upon a vehicle detect at the Order Point.

- Enter the base station configuration mode, see “Enter Configuration Mode” on page 28, and choose **1 System Menu**.
- Change the value for **07 Global Settings > Vibe Alerts on Headsets** to **YES** or **NO**.

## Blue LED Alerts on Headsets

Perform the following procedure to enable or disable the Blue LED Alerts on the Headset upon a vehicle detect at the Order Point.

- Enter the base station configuration mode, see “Enter Configuration Mode” on page 28, and choose **1 System Menu**.
- Change the value for **07 Global Settings > Blue LED Alerts on Headsets** to **YES** or **NO**.

## M. Order Taking Modes Setup

Perform the following procedure to enable or disable some of the seven different order taking modes from appearing on the Run Menu:

- Enter the base station configuration mode, see “Enter Configuration Mode” on page 28, and choose **1 System Menu**.
- Navigate to **09 O.T. Modes Setup**.
- Change the value for each of the following options to **Yes** or **No**:
  - **Manual Listen/Push To Talk**
  - **Manual Listen/Manual Latching Talk**
  - **Auto Listen/Push To Talk**
  - **Auto Listen/Manual Latching Talk**
  - **Hands Free**
  - **Outside**
  - **Always On (Bypass Vehicle Detector)**  
(Press the directional arrows to scroll up and down the list)

### **IMPORTANT NOTE**

Order taking modes are described in the Operation section.

3M recommends you do not set up more than three order taking modes.

## N. Change Site Scheduling

The site schedule is the calendar of store open and closing times.

### **IMPORTANT NOTE**

All timekeeping is done using a 24 hour clock (e.g., 6:00 p.m. appears as 18:00).

## Regular Site Schedule

The regular site schedule is the opening and closing times for each day of the week and the times assigned as “Day” and “Night,” which determine when the day and night volume settings change.

Perform the following procedure to set the regular site schedule:

- Enter the base station configuration mode, see “Enter Configuration Mode” on page 28, and choose **1 System Menu**.
- Navigate to **10 Site Scheduling > Regular Site Schedule**.
- Change the value for each day of the week and each of the four defined fields (**Open, Day, Night, and Close**). (Press the directional arrows to scroll up and down the list).

### IMPORTANT NOTE

The greeter will not play messages while the store is closed, except for the (built-in or custom) store closed message.

## Holiday/Exception Schedule

The holiday/exception schedule can be used to identify up to 12 days in the year on which the store schedule is different than it would have been otherwise. The holiday/exception schedule should be updated at least once a year to ensure it conforms to the current year’s calendar.

Perform the following procedure to set the holiday/exception schedule:

- Enter the base station configuration mode, see “Enter Configuration Mode” on page 28, and choose **1 System Menu**.
- Navigate to **10 Site Scheduling > Holiday/Exception Schedule**.
- For each day that needs a non-typical schedule, enter the three-letter month and two digit date under Date, then change the open and close times on the line to the right of the date. (Press the directional arrows to scroll through the fields).

## O. Change Site Information

Site information is useful for warranty registration and to support service calls. All information is entered free-format using the numeric keypad. To type upper case letters, use the Shift key.

Perform the following procedure to change the site information:

- Enter the base station configuration mode, see “Enter Configuration Mode” on page 28, and choose **1 System Menu**.
- Navigate to **11 Site Information**.
- For each field that needs to be modified, enter the appropriate data. (Press the directional arrows to scroll through the fields).

## P. Digital IO Setup

The Digital IO Setup allows you to configure the 16 logical General Purpose Input and Output ports. All Inputs and Outputs are Active Low. You can reassign any of these GPIO ports to either, provide a signal (OUT) or accept a signal (IN).

You can assign what action the basestation needs to take upon receiving a signal (IN) on one of these ports. The choices are:

- SPLIT/CROSS – change Lane Modes
- ORDER TAKING – toggle through enabled Order Taking Modes
- DAY/NIGHT – change Volume Mode
- EXT\_MSG – Playback assigned message anytime external detector is activated
- VEH\_APP\_1 – Monitor vehicle approach on Lane1
- VEH\_APP\_2 – Monitor vehicle approach on Lane2
- Any Alert messages recorded in the system.

You can integrate any 3M approved external device that can be operated by opening or closing a switch and is independent of the intercom system, to receive a signal (OUT).

The choices are:

- TALK\_1 – TALK channel (Outbound) open on Lane1
- TALK\_2 – TALK channel (Outbound) open on Lane2
- PAGE\_1 – PAGE channel open on Lane1
- PAGE\_2 – PAGE channel open on Lane2
- GRT\_CNCL\_1 – Activate/Stop message playing on external Greeter for Lane1
- GRT\_CNCL\_2 – Activate/Stop message playing on external Greeter for Lane2
- VEH\_DET\_1 – Vehicle detected at Lane1 Order Point
- VEH\_DET\_2 – Vehicle detected at Lane2 Order Point
- Any GPIOs that are currently configured as INPUTS to the basestation (receive a signal or IN)

Perform the following procedure to set up and/or reassign any GPIOs:

- Enter the configuration mode, see “Enter Configuration Mode” on page 28, and choose **1 System Menu**.
- Select **12 Digital IO Setup**.
- Use the directional arrows as necessary to scroll to the desired IO #.
- Change the value for the field IN/OUT and choose the appropriate signal by scrolling down the list presented on the screen (Press the directional arrows to scroll up and down the list).
- At each step press Enter to implement the change or press Mode to abandon the change and retain its original value.

## Q. Change Passcodes

User and installer passcodes can be individualized for better security control against unauthorized changes. The system has a default user and a default installer passcode pre-installed. Check your documentation for those passcodes.

### User Passcodes

If you enter a user passcode, you have full access to the Change User Passcodes menu. You can change or delete any passcode.

Perform the following procedure to set up and/or change user passcodes:

- Enter the configuration mode, see “Enter Configuration Mode” on page 28, and choose **1 System Menu**.
- Select **13 Change Passcodes > Change User Passcodes**.

- Identify the user number you want to change, then press the directional arrows as necessary to scroll to the desired passcode.
- Enter a new four-digit passcode in place of the old passcode.
- Press **Enter** to implement the change or press **Mode** to abandon the change and leave the passcode at its previous setting.

## R. Split and Cross Lane Mode

In any dual lane installation (tandem, side-by-side, or dual drive thrus), the system can be configured to operate registered headsets in Split or Cross Lane Mode. The difference between split lane and cross lane modes in this situation is:

- Split lane mode is intended for a drive thru with two order takers. Each order taker hears beeps only for the lane for which the headset is configured: beeps from the other lane will not be heard.
- Cross lane mode is intended for a drive thru with one order taker who will hear beeps for both lanes on one headset. You can configure the system to permit non-order takers to hear orders and pages from one or both sides. See “Order Takers and Page Messages in Cross Lane Mode” on page 42.

## S. Installer Setup

Installer setup is a special group of setup options typically only used by the installer.

### Load Installation Settings

Installation settings are a complete set of configuration data that the installer can save after the initial installation configuration is completed. It is essentially a backup save point in case configuration settings are inadvertently changed in ways that are not easy to identify or correct.

To load the installation settings:

#### **IMPORTANT NOTE**

By performing this procedure you will be erasing the current configuration and reloading the configuration that was last saved, likely when the system was first installed.

- Enter the configuration mode, see “Enter Configuration Mode” on page 28, and choose **1 System Menu**.
- Select **14 Installer Setup**.
- Change the value for **Load Installation Settings** to **Yes**.
- The system will then reboot.

### Save Installation Settings

#### **IMPORTANT NOTE**

This function is only available to installers.

Perform the following procedure to save the current configuration into permanent memory over the existing installation settings.

#### **IMPORTANT NOTE**

By performing this procedure you will be erasing the existing saved installation settings, making it impossible to revert to the settings that were saved after installation.

- Enter the configuration mode, see “Enter Configuration Mode” on page 28, and choose **1 System Menu**.
- Select **14 Installer Setup**.

- Change the value for **Save Installation Settings** to **Yes**.

## Technical Service Message

Perform the following procedure to customize the Service Screen message.

- Enter the configuration mode, see “Enter Configuration Mode” on page 28, and choose **1 System Menu**.
- Select **14 Installer Setup**.
- Change the value for **Use Custom Tech Service Message?** to **Yes** or **No**.
- If you chose **Yes**, enter the customer message.

## Number of Basestations at this Site

The G5 Basestation Model G5B1 can function as a Single or Dual Lane system. Perform the following procedure to enable the basestation to operate as a dual lane or single lane system:

- Enter the basestation configuration mode, see “Enter Configuration Mode” on page 28, and choose **1 System Menu**.
- Change the value for **14 Installer Setup > Number of Lanes At This Site** to **2**.  
(or to **1** if this is a dual lane system but being installed to function on a single lane)
- Press **Enter** to implement the change.

### IMPORTANT NOTE

The G5 Basestation displays this option only when it's Dual Lane functionality has been activated.

The Dual Lane functionality on the G5 Basestation Model G5B1 is not active, by default, when purchasing a new system. Dual Lane functionality on the G5 Basestation Model G5B1 must be activated by calling **1-800-328-0033**.

## T. Factory Setup (Restore Factory Defaults)

Perform the following procedure to restore all of the configuration settings to the factory default settings. This procedure should be performed only if the current configuration and the saved installation settings are unusable.

### IMPORTANT NOTE

By performing this procedure you will reset the system to the initial configuration, making it impossible to revert to the settings that were saved after installation.

- Enter the configuration mode, see “Enter Configuration Mode” on page 28, and choose **1 System Menu**.
- Select **15 Factory Setup**.
- Change the value of **Restore All Factory Settings** to **Yes**.
- The system will then reboot.

## U. Create and Load Templates

You can save an entire base station configuration as a file on a PC and use the file as a template for other base stations. You must be using a PC to use templates.

## V. Reboot System

Perform the following procedure to cleanly power down, then power up without unplugging the system:

- Enter the configuration mode, see “Enter Configuration Mode” on page 28, and choose **1 System Menu**.
- Select **17 Reboot System**.
- Change the value of **Power Cycle Complete System** to **Yes**.

- Press **Service**.

## W. Check the Revision Levels

Perform the following procedure to view the revision levels and serial numbers of your basestation:

- Enter the configuration mode, see “Enter Configuration Mode” on page 28, and choose **1 System Menu**.
- Select **18 Revision Levels**.

## X. Change the Microphone Preamp Gain

The Mic Preamp Gain is the first stage of amplification from the microphone in the order point. In order to optimize the basestation to a specific site this level must be precisely set.

To change the microphone preamp gain:

- Lookup the microphone’s output level at 1kHz sensitivity (see the microphone’s specifications).
- Enter the configuration mode, see page 37.
- Select a new value for 01 Drivethru Volume > Mic Preamp Gain. The range is 0 to 20. Use the table below to determine the correct setting.

Microphone Output Level	Setting	Microphone Output Level	Setting
-63 dB	0	-74 dB	11
-64 dB	1	-75 dB	12
-65 dB	2	-76 dB	13
-66 dB	3	-77 dB	14
-67 dB	4	-78 dB	15
-68 dB	5	-79 dB	16
-69 dB	6	-80 dB	17
-70 dB	7	-83 dB	18
-71 dB	8	-84 dB	19
-72 dB	9	-85 dB	20
-73 dB	10		

For example, according to its specifications, the 3M™ Duplex Microphone (78-6911-4935-1) has an output level of -71dB at 1 kHz. According to the table, the setting in the basestation should be 8.

### IMPORTANT NOTE

Due to slight microphone variability and cable impedance, you may need to adjust the gain level setting by 1 or 2 dBs.

## Y. Installer Access

The default installer passcode is 12345.



## 4. Troubleshooting

### A. Headset Indicator Lights

The following table describes the operating modes of the headsets according to the indicator lights. Use it as a troubleshooting reference.

**Table B. XT-1 Headset Indicator Light Modes**

Indicator	Mode Description
<b>Off (no light)</b>	Indicates power is off. It will turn off automatically if it fails to register within two minutes or if the battery dies.
<b>Solid Green</b>	Headset is signed on, standby, Lane 1.
<b>Solid Amber</b>	Headset is signed on, standby, Lane 2.
<b>Solid Red</b>	Headset is in transmit mode.
<b>Flashing Green (changed from flashing amber)</b>	Headset has not registered, but found an open base to which it will try to register.
<b>Flashing Green (immediately after power on)</b>	Headset is registered but has not yet synchronized or signed on to the basestation.
<b>Flashing Amber</b>	Headset is not registered and has not found a basestation.
<b>Steadily Flashing Red</b>	Headset is the active order taker, but the outbound talk to the customer is muted.
<b>Single Red Flash (changed from flashing green)</b>	Headset has successfully synchronized and signed on with a basestation ("Lane 1" or "Lane 2" will also be heard in the earpiece).
<b>Alternating Flashing Green and Amber</b>	Page Monitor Mode.
<b>Red -&gt; Orange -&gt; Red -&gt; Green -&gt; Red -&gt; Orange -&gt; Red -&gt; Green</b>	Headset registered to four base stations. Perform the following procedure to clear the headset registration data: 1. Start with the Headset powered on. It does not have to be in sync with any basestation.  2. Press and HOLD the power button.  3. Press and release the T1 button 2 times.  4. Press and release the T2 button 2 times.  5. Release the power button.  The Headset LED will illuminate to solid red for 2 seconds and then it has been cleared.
<b>Flashing in this sequence Red -&gt; 4sec blank -&gt; Red -&gt; 4sec blank</b>	The basestation you are trying to register your headset to, has more than 20 headsets registered already.  Follow the steps below to remove any registered headsets that are not in use any more. 1. Log into the basestation.  2. Press the Mode key until you see the System Menu.  3. Select 04 Registration.  4. Select 02 Remove Headsets.  3. Scroll to the number of the headset you want to un-register.  4. Press Enter.

**Table C. G5 Headset Indicator Light Modes**

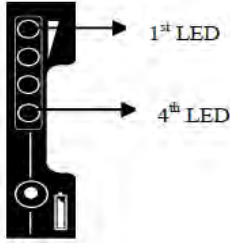
Indicator	Mode Description
<p><b>Green LEDs</b></p> 	<p>The battery is out of the G5 battery Charger and the button has been pressed and held down.</p> <p>Each LED represents 25% charge.            A fully charged battery would have all 4 LEDs lit Green.            From the top (in the diagram on the left) if            4 successive LEDs lit green indicates a charge between 75% and 100%            3 successive LEDs lit green indicates a charge between 50% and 74%            2 LED lit green indicates a charge between 25% and 49%            1 LED lit green indicates a charge between 0% and 24%</p>
<p><b>One of the LEDs is blinking Green</b></p>	<p>The battery is in the Charger and is currently charging            From the top:            1st LED flashing Green – Battery currently between 0 and 25% charge            2nd LED flashing Green – Battery currently between 26 and 50% charge            3rd LED flashing Green – Battery currently between 51 and 75% charge            4th LED flashing Green – Battery currently between 76 and 100% charge</p>
<p><b>Top and Bottom LEDs are Green</b></p>	<p>Battery End of Life.            Replace the battery</p>
<p><b>Bottom LED blinking Green (Battery not in charger)</b></p>	<p>Charge on the battery has depleted below 5% of its State of Charge.            The battery needs to be charged immediately.</p>
<p><b>Off (no light)</b></p>	<p>Indicates power is off.</p> <p>Headset is in sleep / hibernate mode. Picking up (or moving) the headset awakens it and the headset will begin to sign on to the base.</p> <p>Headset was signed on, and then went to SLEEP (lights off after 5 minutes of inactivity). When the headset is moved, it wakes up to SOLID GREEN.</p> <p>Headset was signed on, and then went to SLEEP and then HIBERNATE (total 10 minutes of inactivity). When the headset is moved, it wakes up to Flashing Green (see below).</p> <p>Headset battery is completely out of charge or dead.</p>
<p><b>Solid Green</b></p>	<p>Headset is signed on, Lane 1, no car present, standby</p>
<p><b>Solid Red/Green</b></p>	<p>Headset is signed on, Lane 2, no car present, standby</p>
<p><b>Solid Red</b></p>	<p>Headset is in transmitting mode, ie, headset microphone is live. Either Order Taking, or Page mode.</p>
<p><b>Flashing Red &amp; Green</b></p>	<p>Headset has not registered, but found an open base to which it will try to register.</p>
<p><b>Flashing Green (immediately after power on)</b></p>	<p>Headset is registered but has not yet synchronized or signed on to the basestation.            Headset is out of range of basestation.</p>
<p><b>Flashing Red &amp; Green</b></p>	<p>Headset is not registered and has not found a base station.</p>
<p><b>Steadily Flashing Red</b></p>	<p>Headset is the active order taker, but the outbound talk to the customer is muted.</p>
<p><b>Single Red Flash (changed from flashing green)</b></p>	<p>Short red flash – Battery is inserted            Headset is powering up from Hibernate            Slightly longer red flash – Headset signs on to the base (as it transitions from flashing green to solid green)</p>
<p><b>Alternating Flashing Green and Red</b></p>	<p>Page Monitor Mode.</p>

Indicator	Mode Description
<b>Red -&gt; (Red+Green) -&gt; Red -&gt; Green -&gt; Red -&gt; (Red+Green) -&gt; Red -&gt; Green</b>	<p>Headset registered to four base stations.</p> <p>Perform the following procedure to clear the headset registration data:</p> <ol style="list-style-type: none"> <li>1. Hold down the top end of Volume Control zone with your thumb till you see a Blue light on the end of the mic boom.</li> <li>2. Remove your thumb from the Volume Control zone.</li> <li>3. While the Blue light is still on perform the following sequence in a smooth motion.</li> <li>4. Tap the T1 touch zone 2 times.</li> <li>5. Then, tap the T2 touch zone 2 times</li> <li>6. The Headset LED will blink Red+Green three times and will announce "Powering Off". The headset registration data is now cleared.</li> <li>7. The Headset will momentarily turn off and power back again.</li> </ol>
<b>Flashing in this sequence Red -&gt; 4sec blank -&gt; Red -&gt; 4sec blank</b>	<p>The Base Station you are trying to register your headset to, has more than 20 headsets registered already.</p> <p>Follow the steps below to remove any registered headsets that are not in use any more.</p> <ol style="list-style-type: none"> <li>1. Log into the Basestation.</li> <li>2. Press the Mode key till you see the System Menu.</li> <li>3. Select O4 Registration.</li> <li>4. Select O2 Remove Headsets.</li> <li>5. Scroll to the number of the headset you want to un-register.</li> <li>6. Press Enter.</li> </ol>
<b>Blue (at Mic Boom tip)</b>	<p>Solid blue, when holding the Volume touch zone, indicates that the headset is listening for a special key sequence (e.g. for headset deregistration).</p> <p>Blue flash when vehicle arrives in a lane (in addition to the vehicle present beep (single beep on Lane1 or double beep on Lane 2).</p>

## B. General Troubleshooting

**Table D. General Troubleshooting**

Problem	Possible Cause	Solution
<b>No communications. All headsets have green LED flashing.</b>	The base station has lost power.	Make sure the power transformer is plugged into the wall outlet and into the base station power receptacle. If the LCD display does not come on, check for power at the wall outlet.
	Headsets are not registered to Base Station.	Register headsets.
	The Base Station is defective.	Call for authorized service.
<b>A single headset has green LED flashing.</b>	Headset is not registered to base station.	Register the headset.
	Defective headset.	If the other headsets register OK, the single headset needs repair.
	Headset has lost reception to the basestation.	Move to a line-of-sight location to establish communications again.

Problem	Possible Cause	Solution
<b>No vehicle alert tone in all headsets.</b>	No power to the external vehicle detector.	Plug the vehicle detector into power outlet or replace the detector fuse.
	Vehicle detector is “locked up”.	Remove power to vehicle detector for a few seconds to reset the detector.
	The base station alert tone volume is set too low.	Adjust alert tone volume.
<b>All headsets will not go into Standby (silence) when the vehicle leaves the menu sign.</b>	This is normal when a pulse (air switch) type of vehicle detector is used.	Press the Page switch to silence the menu microphone.
	There is a large metal object near the loop in the driveway (if a loop is used).	Remove the object.
	The Loop detector is “locked up”.	Unplug the loop detector from the AC outlet and plug it back in to reset the detector.
	Defective vehicle detector.	Call for authorized service.
	System is in Always On order taking mode.	Change the talking mode.
<b>Audio on all headsets cuts out or is interrupted.</b>	The Backup Intercom is on (the switch is engaged).	Disengage the Backup Intercom switch on the basestation.
	Loose or frayed wiring.	Call for authorized service.
	Poor location of Base Station antennae (behind large metal objects, too far from work area, etc.).	Relocate the Base Station, or antennae.
<b>Inbound audio cuts out (but outbound audio is okay).</b>	The AEC level is too high.	Reduce the AEC level.
	The headset is too close to loud ambient noise.	Move the headset away from sources of loud ambient noise.
<b>No Talk or listen from the menu sign when using the backup wired intercom. G5 Basestation Model G5B1 works OK.</b>	The backup switch on the base station is not in the correct position.	Turn the backup switch ON.
	No power to the backup intercom.	Turn the backup intercom on or plug in its power transformer.
	The volume controls are set too low on the backup intercom.	Turn the volume controls up.
	Defective backup intercom or wiring.	Call for authorized service.
<b>No Talk or Page to other headsets from a single headset, or Talk or Page buttons require excessive pressure to operate.</b>	Worn or defective Talk or Page switch.	Call for authorized service.
	Defective XT-1 headset or defective G5 Pod or Carrier.	
<b>Low Talk volume on a single headset.</b>	The holes in front of the microphone are plugged with dirt or grease.	Call for authorized service.
	Operator is not positioning the microphone correctly.	Adjust/reposition the headset microphone(s).
	Defective XT-1 headset or defective G5 Pod or Carrier.	Call for authorized service.
	Volume setting on headset is too low.	Power off and power on headset to reset volume level.
<b>Louder Talk volume or feedback from a single headset.</b>	Volume setting on headset is too high.	Power off and power on headset to reset volume level.
	The holes in back of the microphone are plugged with dirt or grease.	Call for authorized service.

Problem	Possible Cause	Solution
<b>The “hands free” function does not work.</b>	The system is operating in half duplex mode.	Hands Free is disabled in half duplex mode.
	Hands free order taking mode not selected.	Select hands free order taking mode in the basestation.
<b>No vehicle alert tone in headset.</b>	Backup switch not completely pressed (i.e., one of the other two buttons is pressed).	Press the other button into the correct location.
<b>XT-1Headset(s) amber LED flashing G5 Headset(s) Green &amp; Red LED flashing.</b>	Headset(s) not registered.	Register the headset(s).
<b>Headsets say “Out of Range”.</b>	Possible WiFi congestion in the store.	Move the operating channels on all the WiFi Access Points to Channel 11.
	A WiFi Access Point (to provide WiFi to dining guests) is very close to the basestation	Move the Access Point to at least 15 feet away from the basestation.
	You are operating the headset outside of its normal operating range of the store environment.	Walk the headset back towards the basestation. If the range to this area is required, consider installing a 3M Range Extender. Call for authorized service to help.
<b>Inbound and Outbound audio completely lost on headset and/or on ALL headsets.</b>		Unplug the power to the basestation, wait for a couple seconds and re-plug the power to the basestation.
<b>The basestation displays the message “MSP FAIL: No Memory left for Allocation”.</b>	Vehicle detection or other GPIO is active during the boot process.	Unplug the power to the basestation, wait for a couple seconds and re-plug the power to the basestation.
<b>The basestation displays the message “Info audio test failed – rebooting”.</b>		Unplug the power to the basestation, wait for a couple seconds and re-plug the power to the basestation.

**i IMPORTANT NOTE**

**Basestation Reboot Time**

Anytime you reboot the basestation either by:

- Using Menu option 17 of the System Menu (as described in “Reboot System” on page 47).
- Disconnecting the main power to the basestation, waiting for 10 seconds, and then connecting the power back to the basestation,

it may take anywhere between 2:40 minutes to 3:15 minutes for the basestation to become operational.

You can either disconnect the power to the basestation by unplugging the:

- Barrel Plug at the basestation (after removing the cover to the basestation) or
- 3-pin plug to the wall socket (that provides the power).

Both procedures are illustrated in Figure 28.

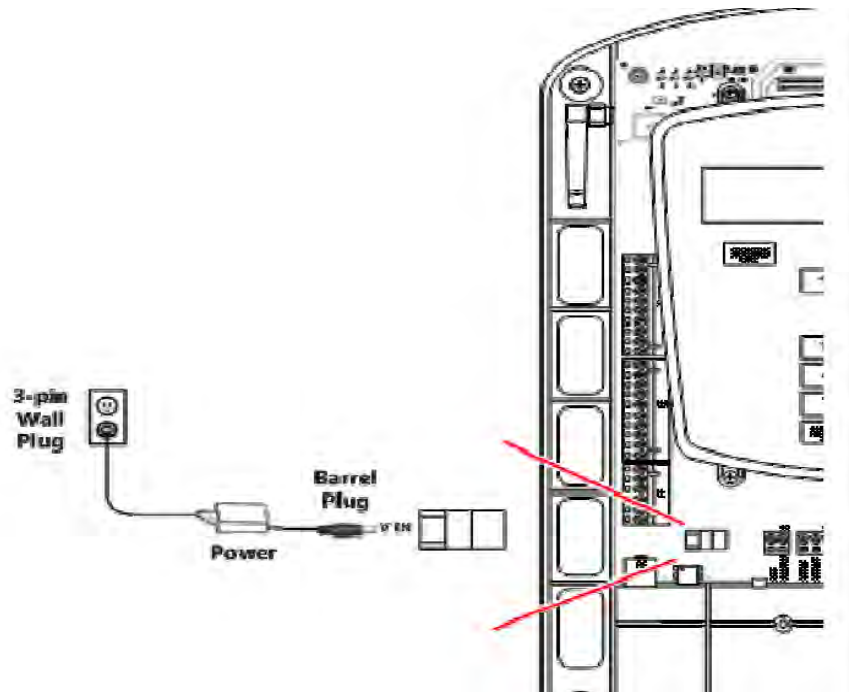

Figure 28.

## C. Battery and Battery Charger Troubleshooting

Table E. XT-1 Battery and Battery Charger

Problem	Possible Cause	Solution
<b>No lights come on when a battery is inserted into charger.</b>	Dirty contacts on battery or charger.	Clean contacts on battery and charger.
	No power to charger.	Make sure power transformer is plugged into charger and a "live" outlet.
	Defective battery.	Try a known good battery.
	Defective charger.	Call for authorized service.
<b>Short battery life.</b>	Worn out batteries.	Replace battery.
	Wrong type of power transformer used for charger.	Make sure power transformer is marked "Secondary Voltage 14 VAC".
<b>The green light on the charger never comes on.</b>	Defective battery.	Replace the battery.

**Table F. G5 Battery Indicator Light Modes**

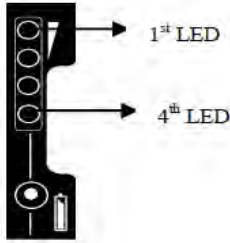
Indicator	Mode Description
<p><b>Green LEDs</b></p> 	<p>The battery is out of the G5 battery Charger and the button has been pressed and held down.</p> <p>Each LED represents 25% charge.            A fully charged battery would have all 4 LEDs lit Green.            From the top (in the diagram on the left) if            4 successive LEDs lit green indicates a charge between 75% and 100%            3 successive LEDs lit green indicates a charge between 50% and 74%            2 LED lit green indicates a charge between 25% and 49%            1 LED lit green indicates a charge between 0% and 24%</p>
<p><b>One of the LEDs is blinking Green</b></p>	<p>The battery is in the Charger and is currently charging            From the top:            1st LED flashing Green – Battery currently between 0 and 25% charge            2nd LED flashing Green – Battery currently between 26 and 50% charge            3rd LED flashing Green – Battery currently between 51 and 75% charge            4th LED flashing Green – Battery currently between 76 and 100% charge</p>
<p><b>Top and Bottom LEDs are Green</b></p>	<p>Battery End of Life.            Replace the battery</p>

## 5. Appendix: Declaration of Conformity

<b>The Company Name</b> 3M Company	
<b>The Company Address</b> 3M Building & Commercial Services Division 3M Center - Building 250-03-W-04 St. Paul, MN 55144-1000	

**Declares that the product(s):**

<b>Product Name and/or Model Number(s)</b> These products are optional accessories that can be used in conjunction with the 3M(TM) Wireless Communications System Model XT-1. Some of the optional accessory items have the potential to be connected to the XT-1 System via a 180 ft cable.
<b>Type and/or Description</b> Wireless Communications System Accessories: <ul style="list-style-type: none"> <li>• 3M™ Microphone, Duplex, With Bracket</li> <li>• 3M™ Microphone, Duplex System-Plate Mount</li> <li>• 3M™ Speaker Assembly, Duplex, 5 in</li> <li>• 3M™ Magnetic Loop, Pre-Fab</li> <li>• 3M™ Magnetic Loop Detector - Internal</li> <li>• 3M™ Magnetic Loop Kit, Saw-in</li> <li>• 3M™ Cable, 3 Pair, Twisted Combination Duplex, 180 ft.</li> <li>• Sonic Detector Interface</li> <li>• 3M™ Wireless Comm System, Model XT-1, International Demo Kit</li> <li>• 3M™ Wireless Comm System, Model XT-1, Software Upgrade Kit</li> </ul>

**Conform(s) to the following specifications:**

<b>Directives</b> 2011/65/EU    RoHS II Directive
<b>Year in which CE mark first affixed</b> 2013
<b>Standards</b> EN50581:2012                      Restriction of Hazardous Substances
<b>Quality System</b> Manufacturer qualified based on ISO 9002/EN 29002

<b>Signer of Declaration</b> Sue Wculfe	<b>Title</b> Technical Director Building & Commercial Services Division
<b>Signature</b> 	<b>Date</b> 02/05/13



## EU Declaration of Conformity CE

<b>Company</b> 3M Company	<b>Division</b> 3M Commercial Solutions Division
<b>Address</b> 3M Center - Building 260-3W-04 St. Paul, MN 55144-1000 USA	

**Does hereby declare under our sole responsibility that this equipment or product(s) comply with the applicable essential requirements of the legislation listed below; along with the referenced standards or specifications.**

<b>Object - Product name and/or model number(s) and/or unique identification:</b> 3M™ Drive-Thru System XT-1 Basestation, Model XT-1B
<b>Type and/or description and/or intended purpose or equipment class and/or particular conditions applicable to the use of the Object:</b> The 3M™ Drive-Thru System Wireless Communication XT-1B Basestation is intended for use in drive-through applications (quick-service restaurants, etc.).
<b>Serial number or range (if applicable):</b>

**Conforms to the following Union harmonization legislation; together with all amendments to-date:**

<b>Directives:</b>	
2014/53/EU RED	
2011/65/EU Restriction of the use of certain hazardous substances	
<b>Standards / specifications / provisions complied with; in full or in part as applicable:</b>	
EN 60950-1:2006 + A11:2009 + A1:2010 + A12:2011 + A2:2013	Information technology equipment - Safety (2nd Edition) – Part 1: General requirements
EN 301 489-1 V1.9.2	Electromagnetic compatibility and Radio spectrum Matters (ERM); ElectroMagnetic Compatibility (EMC) standard for radio equipment and services; Part 1: Common technical requirements
EN 301 489-17 V2.2.1	Electromagnetic compatibility and Radio spectrum Matters (ERM); ElectroMagnetic Compatibility (EMC) standard for radio equipment; Part 17: Specific conditions for Broadband Data Transmission Systems
EN 300 328 V1.9.1	Electromagnetic compatibility and Radio spectrum Matters (ERM); Wideband transmission systems; Data transmission equipment operating in the 2,4 GHz ISM band and using wide band modulation techniques
EN 300 330-2 V1.5.1	Electromagnetic compatibility and Radio spectrum Matters (ERM); Short Range Devices (SRD); Radio equipment in the frequency range 9 kHz to 25 MHz and inductive loop systems in the frequency range 9 kHz to 30 MHz; Part 2: Harmonized EN covering the essential requirements of article 3.2 of the R&TTE Directive
EN 50385:2002	Product standard to demonstrate the compliance of radio base stations and fixed terminal stations related to human exposure to radio frequency electromagnetic fields (110 MHz - 40 GHz) - General public
EN 50581:2012	Restriction of Hazardous Substances

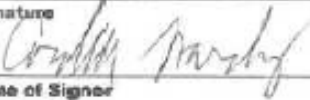
<b>Signature</b> 	<b>Date</b> 9/7/16	<b>Place</b> Maplewood, MN USA
<b>Name of Signer</b> Mike Kesti	<b>Title</b> Technical Director, Commercial Solutions Division	

## EU Declaration of Conformity CE

<b>Company</b> 3M Company	<b>Division</b> Commercial Solutions Division
<b>Address</b> 3M Center - Building 280 St. Paul, MN 55144-1000 USA	

**Does hereby declare under our sole responsibility that this equipment or product(s) comply with the applicable essential requirements of the legislation listed below, along with the referenced standards or specifications.**

<b>Object - Product name and/or model number(s) and/or unique identification:</b> C932 - 3 Bay Battery Charger C936 - 6 Bay Battery Charger
<b>Type and/or description and/or intended purpose or equipment class and/or particular conditions applicable to the use of the Object:</b> 15 Vdc, 1.2A Battery Chargers for Use with 3M C1050/KT-1 Lithium Ion Battery Pack
<b>Serial number or range (if applicable):</b>

**Conforms to the following Union harmonization legislation, together with all amendments to-date:**

<b>Directives:</b> 2014/53/EU RED 2011/65/EU Restriction of the use of certain hazardous substances	
<b>Standards / specifications / provisions complied with, in full or in part as applicable:</b>	
EN 60950-1:2006 + A11:2009 + A1:2010 + A12:2011 + A2:2013	Information technology equipment - Safety (2 <sup>nd</sup> Edition) - Part 1: General Requirements
EN 50581:2012	Restriction of Hazardous Substances
<b>EMC Emissions (Class "A"):</b>	
EN 55022/CISPR 22	Radiated Emissions, Class B, 30 MHz - 1000 MHz
EN 55022/CISPR 22	Conducted Emissions, Class A, 0.15 MHz - 30 MHz
EN 61000-3-2	Harmonic Emissions
EN 61000-3-3	Flicker
<b>EMC Immunity:</b>	
EN 61000-4-2/IEC 61000-4-2	Electrostatic Discharge (ESD)
EN 61000-4-3/IEC 61000-4-3	Radiated Immunity
EN 61000-4-4/IEC 61000-4-4	Electrical Fast Transient (EFT)
EN 61000-4-5/IEC 61000-4-5	Surge
EN 61000-4-6/IEC 61000-4-6	Conducted Immunity
EN 61000-4-11/IEC 61000-4-11	Voltage Dips and Interrupt

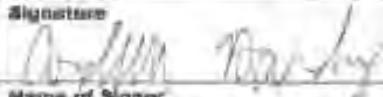
<b>Signature</b> 	<b>Date</b> 8/7/16	<b>Place</b> Maplewood, MN, USA
<b>Name of Signer</b> Cordell Hardy	<b>Title</b> Technical Director, Commercial Solutions Division	

## EU Declaration of Conformity CE

<b>Company</b> 3M Company	<b>DIVISION</b> 3M Commercial Solutions Division
<b>Address</b> 3M Center - Building 250-3W-04 St. Paul, MN 55144-1000 USA	

**Does hereby declare under our sole responsibility that this equipment or product(s) comply with the applicable essential requirements of the legislative listed below, along with the referenced standards or specifications.**

<b>Object - Product name and/or model number(s) and/or unique identification:</b> 3M™ C1060/XT-1 Battery Pack
<b>Type and/or description and/or intended purpose or equipment class and/or particular conditions applicable to the use of the Object:</b> The 3M™ Drive-Thru System Wireless Communication C1060/XT-1 Battery Pack is intended for powering XT-1 Headset, and used in drive-through applications (quick-service restaurants, etc.).
<b>Serial number or range (if applicable):</b>

**Conforms to the following Union harmonization legislation; together with all amendments to-date:**

<b>Directives:</b>	
2001/95/EC	General Product Safety Directive (GPSD)
2011/65/EU	Restriction of the use of certain hazardous substances
<b>Standards / specifications / protocols complied with; in full or in part as applicable:</b>	
EN 62133:2013	Secondary cells and batteries containing alkaline or other non-acid electrolytes – Safety requirements for portable sealed secondary cells, and for batteries made from them, for use in portable applications
EN 50581:2012	Restriction of Hazardous Substances

<b>Signature</b> 	<b>Date</b> 11/19/2015	<b>Place</b> Maplewood, MN USA
<b>Name of Signer</b> Mike Kesti	<b>TITLE</b> Technical Director, Commercial Solutions Division	

## EU Declaration of Conformity CE

<b>Company</b> 3M Company	<b>Division</b> 3M Commercial Solutions Division
<b>Address</b> 3M Center - Building 250-3W-04 St. Paul, MN 55144-1000 USA	

I/We hereby declare under our sole responsibility that this equipment or product(s) comply with the applicable essential requirements of the legislation (listed below) along with the referenced standards or specifications.

**Object - Product name and/or model number(s) and/or unique identification:**

3M™ Drive-Thru System G5 Basestation, Model G5B1

**Type and/or description and/or intended purpose or equipment class and/or particular conditions applicable to the use of the Object:**

The 3M™ Drive-Thru System Wireless Communication G5 Basestation is intended for use in drive-through applications (quick-service restaurants, etc.).

**Serial number or range (if applicable):**

Conforms to the following Union harmonization legislation, together with all amendments to date:

**Directives:**

2014/53/EU RED

2011/65/EU Restriction of the use of certain hazardous substances

**Standards / specifications / provisions complied with, in full or in part as applicable:**

EN 60950-1:2006 + A11:2009 + A1:2010 + A2:2011 + A2:2013	Information technology equipment - Safety (2nd Edition) - Part 1: General requirements
EN 301 489-1 V1.9.2	Electromagnetic compatibility and radio spectrum Matters (ERM); ElectroMagnetic Compatibility (EMC) standard for radio equipment and services, Part 1: Common technical requirements
EN 301 489-17 V2.2.1	Electromagnetic compatibility and radio spectrum Matters (ERM); ElectroMagnetic Compatibility (EMC) standard for radio equipment, Part 17: Specific conditions for Broadband Data Transmission Systems
EN 300 328 V1.9.1	Electromagnetic compatibility and radio spectrum Matters (ERM); Wideband transmission systems; Data transmission equipment operating in the 2.4 GHz ISM band and using wide band modulation techniques
EN 300 330-2 V1.5.1	Electromagnetic compatibility and radio spectrum Matters (ERM); Short Range Devices (SRD); Radio equipment in the frequency range 9 kHz to 25 MHz and inductive loop systems in the frequency range 9 kHz to 30 MHz; Part 2: Harmonized EN covering the essential requirements of article 3.2 of the R&TTE Directive
EN 50385:2002	Product standard to demonstrate the compliance of radio base stations and fixed terminal stations related to human exposure to radio frequency electromagnetic fields (110 MHz - 40 GHz) - General public
EN 50581:2012	Restriction of Hazardous Substances

<b>Signature</b> 	<b>Date</b> 9/7/16	<b>Place</b> Maplewood, MN, USA
<b>Name of Signer</b> Cordell Harpy	<b>Title</b> Technical Director, Commercial Solutions Division	

## EU Declaration of Conformity CE

<b>Company</b> 3M Company	<b>Division</b> Commercial Solutions Division
<b>Address</b> 3M Center – Building 280 St. Paul, MN 55144-1000 USA	

**Does hereby declare under our sole responsibility that this equipment or product(s) comply with the applicable essential requirements of the legislation listed below, along with the referenced standards or specifications.**

<b>Object - Product name and/or model number(s) and/or unique identification:</b> 3M™ Drive-Thru Headset Battery Charger G5, 12-Slot, Model G5E1 3M™ Drive-Thru Headset Battery Charger G5, 10-Slot, Model G5F1 3M™ Battery G5, Model G5L3
<b>Type and/or description and/or intended purpose or equipment class and/or particular conditions applicable to the use of the Object:</b> G5 Wireless Communication System Battery Chargers and G5 Battery Pack
<b>Serial number or range (if applicable):</b>

**Conforms to the following Union harmonization legislation; together with all amendments to-date:**

<b>Directives:</b> 2014/53/EU RED 2011/65/EU Restriction of the use of certain hazardous substances												
<b>Standards / specifications / provisions complied with, in full or in part as applicable:</b>												
<table style="width: 100%; border: none;"> <tr> <td style="width: 30%; padding: 2px;">EN 60950-1:2006 + A11:2009 + A1:2010 + A12:2011 + A2:2013</td> <td style="padding: 2px;">Information technology equipment - Safety (2nd Edition) – Part 1: General requirements</td> </tr> <tr> <td style="padding: 2px;">EN 61000-3-2:2006 + A1:2009 + A2:2009</td> <td style="padding: 2px;">Electromagnetic compatibility (EMC) – Part 3-2: Limits – Limits for harmonic current emissions</td> </tr> <tr> <td style="padding: 2px;">EN 61000-3-3:2008</td> <td style="padding: 2px;">Electromagnetic compatibility (EMC) – Part 3-3: Limits – Limitation of voltage changes, voltage fluctuations and flicker in public low-voltage supply systems</td> </tr> <tr> <td style="padding: 2px;">EN 61326-1:2013</td> <td style="padding: 2px;">Electrical equipment for measurement, control and laboratory use – EMC requirements – Part 1: General requirements</td> </tr> <tr> <td style="padding: 2px;">EN 62133:2013</td> <td style="padding: 2px;">Secondary cells and batteries containing alkaline or other non-acid electrolytes. Safety requirements for portable sealed secondary cells, and for batteries made from them, for use in portable applications</td> </tr> <tr> <td style="padding: 2px;">EN 50581:2012</td> <td style="padding: 2px;">Restriction of Hazardous Substances</td> </tr> </table>	EN 60950-1:2006 + A11:2009 + A1:2010 + A12:2011 + A2:2013	Information technology equipment - Safety (2nd Edition) – Part 1: General requirements	EN 61000-3-2:2006 + A1:2009 + A2:2009	Electromagnetic compatibility (EMC) – Part 3-2: Limits – Limits for harmonic current emissions	EN 61000-3-3:2008	Electromagnetic compatibility (EMC) – Part 3-3: Limits – Limitation of voltage changes, voltage fluctuations and flicker in public low-voltage supply systems	EN 61326-1:2013	Electrical equipment for measurement, control and laboratory use – EMC requirements – Part 1: General requirements	EN 62133:2013	Secondary cells and batteries containing alkaline or other non-acid electrolytes. Safety requirements for portable sealed secondary cells, and for batteries made from them, for use in portable applications	EN 50581:2012	Restriction of Hazardous Substances
EN 60950-1:2006 + A11:2009 + A1:2010 + A12:2011 + A2:2013	Information technology equipment - Safety (2nd Edition) – Part 1: General requirements											
EN 61000-3-2:2006 + A1:2009 + A2:2009	Electromagnetic compatibility (EMC) – Part 3-2: Limits – Limits for harmonic current emissions											
EN 61000-3-3:2008	Electromagnetic compatibility (EMC) – Part 3-3: Limits – Limitation of voltage changes, voltage fluctuations and flicker in public low-voltage supply systems											
EN 61326-1:2013	Electrical equipment for measurement, control and laboratory use – EMC requirements – Part 1: General requirements											
EN 62133:2013	Secondary cells and batteries containing alkaline or other non-acid electrolytes. Safety requirements for portable sealed secondary cells, and for batteries made from them, for use in portable applications											
EN 50581:2012	Restriction of Hazardous Substances											

<b>Signature</b> 	<b>Date</b> 9/7/13	<b>Place</b> Maplewood, MN USA
<b>Name of Signer</b> Cordell Hardy	<b>Title</b> Technical Director, Commercial Solutions Division	

## EU Declaration of Conformity CE

<b>Company</b> 3M Company	<b>Division</b> Commercial Solutions Division
<b>Address</b> 3M Center - Building 280 St. Paul, MN 55144-1000 USA	
Does hereby declare under our sole responsibility that this equipment or product(s) comply with the applicable essential requirements of the legislation listed below, along with the referenced standards or specifications.	
<b>Object - Product name and/or model number(s) and/or unique identification:</b> 3M™ Drive-Thru Headset G5, Model G5H1 3M™ Battery G5, Model G5L1	
<b>Type and/or description and/or intended purpose or equipment class and/or particular conditions applicable to the use of the Object:</b> G5 Wireless Communication System Headset with Battery pack, for use in quick service drive-through applications	
<b>Serial number or range (if applicable):</b>	

Conforms to the following Union harmonization legislation together with all amendments to-date:

<b>Directives:</b> 2014/53/EU RED 2011/65/EU Restriction of the use of certain hazardous substances	
<b>Standards / specifications / provisions complied with in full or in part as applicable:</b>	
EN 60950-1:2006 + A11:2009 + A1:2010 + A12:2011 + A2:2013 EN 300 328 V1.9.1	Information technology equipment - Safety (2nd Edition) - Part 1: General requirements  Electromagnetic compatibility and Radio spectrum Matters (ERM); Wideband transmission systems; Data transmission equipment operating in the 2.4 GHz ISM band and using wide band modulation techniques
EN 301 489-3 V1.8.1	Electromagnetic compatibility and Radio Spectrum Matters (ERM); Part 3: Common technical requirements
EN 301 489-17 V2.1.1	Electromagnetic compatibility and Radio spectrum Matters (ERM); Electromagnetic Compatibility (EMC) standard for radio equipment; Part 17: Specific conditions for Broadband Data Transmission Systems
EN 62133:2013	Secondary cells and batteries containing alkaline or other non-acid electrolytes. Safety requirements for portable sealed secondary cells, and for batteries made from them, for use in portable applications
EN 50581:2012 EN 50566:2013	Restriction of Hazardous Substances Product standard to demonstrate compliance of radio frequency fields from handheld and body-mounted wireless communication devices

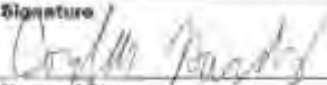
<b>Signature</b> 	<b>Date</b> 9/7/16	<b>Place</b> Maplewood, MN USA
<b>Name of Signer</b> Crystell Hardy	<b>Title</b> Technical Director, Commercial Solutions Division	

## 6. Appendix: Basestation Specifications

### A. Physical

Parameter	Specification or Requirement
<b>Dimensions (l x w x d)</b>	16 ¾ in. x 11½ in. x 2 in. (41.8 cm x 29 cm x 5 cm)

### B. Electrical

Parameter	Specification or Requirement
<b>Input Power</b>	120 VAC, 50/60 Hz, 15A Standard 3-prong outlet required (station includes AC adapter)
<b>Radio Frequency</b>	2401.92 MHz - 2479.68 MHz ISM
<b>Maximum Output Power (EIRP)</b>	20 dBm
<b>Speaker Outputs</b>	5W

### C. Functional

Parameter	Specification or Requirement
<b>Maximum number of order points per basestation</b>	2
<b>Maximum number of headsets per basestation</b>	More than 20
<b>Maximum number of vehicle detectors per basestation</b>	2
<b>Greeter functionality</b>	Built-in
<b>Operating Temperature Range</b>	41°F (5°C) to 104°F (40°C)
<b>Humidity</b>	95% max, non-condensing
<b>Maximum Altitude</b>	2000 meters

### D. Antennas

This radio transmitter G5 Basestation Model G5B1 has been approved by Industry Canada and FCC to operate with the antenna types listed below with the maximum permissible gain indicated. Antenna types not included in this list, having a gain greater than the maximum gain indicated for that type, are strictly prohibited for use with this device.

The following antenna types have been tested and approved for use with the Basestation

Model: RUB09A-2400-SMA, 1/2 wave, Monopole Antenna, Gain 0dBi

Model: HG2408P, Round Patch Antenna, Gain 8dBi

Model: HGV-2409U, Omni directional Antenna, Gain 8dBi

#### IMPORTANT NOTE

Basestation may only be used with antennas that have been tested and approved for use with this Basestation.

### E. Magnetic Loop Detectors

This radio transmitter G5 Basestation Model G5B1 has been approved to operate with the magnetic loop detectors listed below. These are optional loop detectors, limit 2. The frequency range is 50 -75 kHz. The loop are should not exceed 0.63 m2 (6.75ft2).

## 7. Appendix: Induction Loop and Vehicle Detector Board Specifications

### A. Internal Vehicle Detector Board Specifications

Parameter	Specification or Requirement
<b>Size</b>	2.5 in. x 3.0 in. (5.1 cm x 7.6 cm)
<b>Power Supply Type</b>	Supply from G5 Base Station G5B1 terminals
<b>Voltage</b>	12 DC nominal
<b>Current</b>	50 mA maximum
<b>Connector</b>	3 wire plug in connector to G5 BaseStation G5B1

### B. Saw - In Loop Specifications

Parameter	Specification or Requirement
<b>3M Detector Loop Sealant</b>	2 each, 1 quart cartridges.
<b>Power Supply Type</b>	14 AWG, 19 strands of bare copper, .015 polyvinyl chloride insulation with .004 nylon jacket, 600v U.L. listed as 90 degree Celsius MTW, gasoline and oil resistant, 100 feet long.

### C. Prefab Loop Specifications

Parameter	Specification or Requirement
<b>Loop Inductance</b>	100 micro henries
<b>Loop Tubing</b>	1/2" schedule 40 PVC
<b>Loop Wire</b>	5 turns of 18 AWG, 7 strands copper with poly vinyl chloride insulation
<b>Lead - in cable</b>	20 feet of 2 conductor (plus shield) 16 AWG. 19 x 29 stranded copper, Mylar shield with 20 AWG Drain wire. Outer jacket to be of high density polyethylene, suitable for direct burial



## 8. Appendix: G5 Charger Specifications

### A. Physical

Parameter	Specification or Requirement	
	G5 Desk Charger	G5 Wall Charger
<b>Dimensions (l x w x d)</b>	6.4" x 5.6" x 2.0" (162mm x 143mm x 51mm)	19.5" x 3.2" x 2.7" (495mm x 81mm x 68mm)
<b>Weight (fully loaded)</b>	1.3 lbs (0.6kg)	2.9 lbs (1.3kg)

### B. Electrical

Parameter	Specification or Requirement	
	G5 Desk Charger	G5 Wall Charger
<b>Input Power (at full load)</b>	23 watts	16 watts
<b>Input Voltage Requirement</b>	100-240V~, 50-60hz (Note: G5 chargers must be used with 3M-supplied power adaptor)	

### C. Functional

Parameter	Specification or Requirement	
	G5 Desk Charger	G5 Wall Charger
<b>Maximum Operating Temperature</b>	90°F (32°C)	
<b>Humidity</b>	95% max, non-condensing	

## 9. Appendix: Best Practices

This appendix provides best practices to help ensure successful configuration and operation of G5 Basestation Model G5B.

### A. PreAmp Setting

Set the PreAmp gain setting according to the type of wiring you are using:

- If you are using the provided 3M Microphone and the 20 AWG cable, set the PreAmp gain setting to 8.
- If a 22 AWG cable is used, set the PreAmp gain setting to 9.

### B. Volume Control

Here are some guidelines:

- If you are using the provided 3M Microphone and you set the PreAmp gain setting to a value over 10, you could cause distortion and echoes on the inbound channel.
- If the customer wants the inbound communication at a higher volume level, set the inbound volume control to a higher level, or show the customer how to increase the headset volume.
- Do not increase the volume using the PreAmp gain. The PreAmp is designed to optimize G5 Basestation Model G5B1 and the Microphone and should not be used to increase the volume level.

### C. Optimizing Installation

The following steps may reduce the possibility of customer complaints and may decrease your installation time:

- Power Supply Mounting – mount the power supply in a safe place where it will not get disconnected.
- Use strain relief on all connections – G5 Basestation Model G5B1 was designed so that all connections would be strain relieved and therefore minimizing the chance of a connector being disconnected.
- Use an Uninterruptible Power Supply (UPS) – adding a UPS will make G5 Basestation Model G5B1 more reliable by increasing uptime as providing a cleaner power source.
- Use a Pre-install Checklist.
- Use an Installation Checklist.
- Remove the Microphone Cover (Adhesive disk protecting the front of the microphone), if still present.

## D. Dealing with Delay/Echo

During the first ½ second of each order, there is a delay while the Order Taker starts to speak. If the Delay lasts more than a ½ second, follow the flowchart (Figure 29) below. You may also experience a delay if a vehicle at the order point moves while the order is taking place; this usually happens at the end of a call while the order taker tells the customer the total.

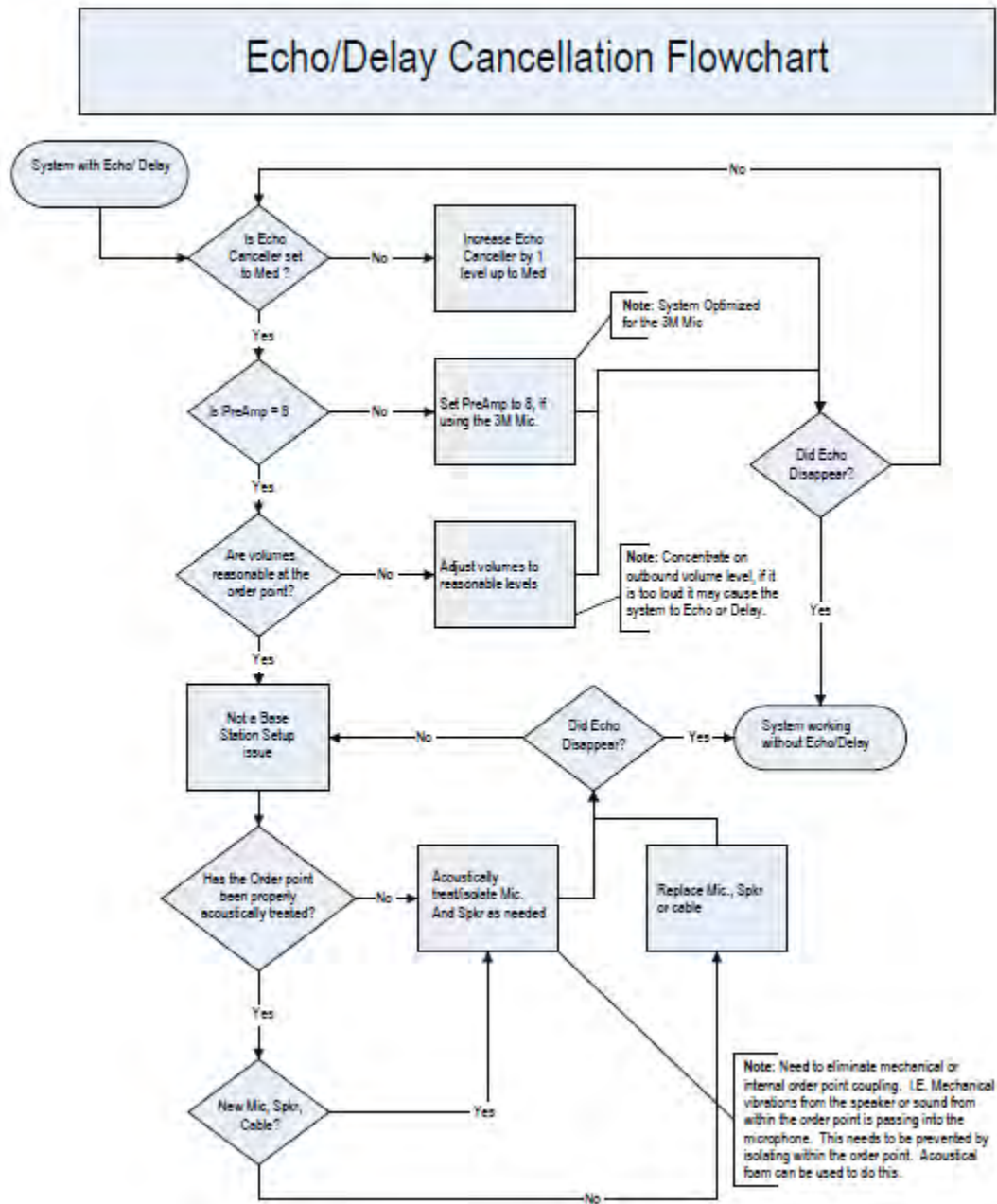

Figure 29.

## 10. Appendix: 3M™ Acoustic Kit Installation Guide

The 3M™ Acoustic Kit that is used for communication posts is suitable for new or retrofit installations and can readily be used with various housing designs. One kit contains enough material to accommodate a typical microphone and speaker system. It can be used for a microphone and speaker installed either in a single housing or in separate housings.

When installed according to the guidelines below, these components act together as a system to help enhance speech intelligibility.

### A. System Components

- 6 each, 2" x 10" 3M™ Vibration Control Tape
- 2 each, 1" x 8" x 27" TUFECOTE® TBK Faced Foam
- 2 each, 2" x 12" x 30" Thinsulate™ Acoustic Insulation



### B. Installation Guidelines - Separate Housings

Component installation is the same for both the microphone and the speaker housings.

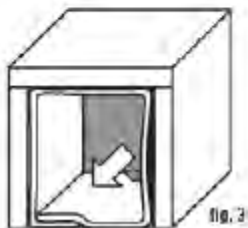
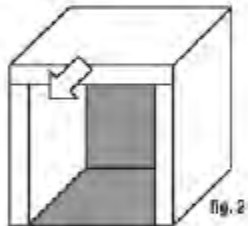
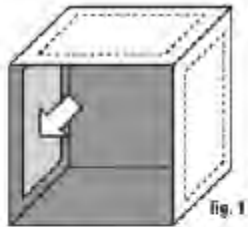

- Ensure that the inside of the housing is clean and dry.
- Install the 3M™ Vibration Control Tape to the inside of the top and side walls of the housing (fig. 1).
  - Using a pair of scissors, cut one piece of tape approximately 1" less than the length of the top wall. Cut two pieces so they are each approximately 1" less than the side walls.
  - Peel and discard the release liner from the back of the tape.
  - Center each piece of tape on the inside of the top and side walls of the housing, as shown in the illustration.
- Install the TUFECOTE® TBK Faced Foam to the inside of the housing and over the vibration control tape (fig. 2).
  - Check the fit of the foam to the inside of the housing. The foam can either be formed into an upside-down "u" shape to fit against the inside of the top and side walls as one piece, or cut into individual pieces to fit the inside of each wall.
  - Peel and discard the release liner from the back of the faced foam.
  - Align the center of the foam with the centerline of the top wall and then work toward the edges until the foam is centered on the inside of the top and side walls of the cavity.
  - When positioned correctly, press the foam firmly to secure it in place.
- Install the Thinsulate™ Acoustic Insulation (fig. 3).
  - Loosely line the housing with the acoustic insulation. For the best appearance, position the black side of the insulation toward the outside of the housing.
  - If there is excess insulation, overlap it against the inside of the first layer.

## C. Installation Guidelines - Single Housing

Microphone and speaker are contained within a single housing. Component installation is the same for both microphone and the speaker. The microphone and speaker must be separated from each other by foam.

- Ensure that the inside of the housing is clean and dry.
- Install the 3M™ Vibration Control Tape to the inside of the top and side walls of the housing (fig.4).
  - Using a pair of scissors, cut one piece of tape to be approximately 1" less than the length of the inside of the top wall. The four pieces of tape used for the side walls can be used as is from the kit and do not require trimming.
  - Peel and discard the release liner from the back of the tape.
  - Center a piece of tape on the inside of the top of the housing. Locate the position of the microphone (speaker) and center a piece of tape on the inner wall of the housing centered with the microphone. Repeat for the opposite wall. Repeat this step for the speaker.
- Install the TUFECOTE® TBK Faced Foam to the inside of the housing and over the vibration control tape (fig. 5).
  - Standard method:

Cut one piece of foam to be positioned between the speaker and microphone. In order for the foam to fit securely, cut it slightly larger than the inner dimensions of the housing. It should fit snugly between the walls of the housing without buckling.

Check the fit of the faced foam to the inside of the housing, in the areas adjacent to the microphone and the speaker. Cut into individual pieces to fit the inside of each wall of the housing as shown in the illustration.
  - Alternative method:

Form one piece of insulation into a "u" shape and position it in the upper pan of the housing.

Form the second piece of insulation into an upside-down "u" shape and position it in the lower pan of the housing.
  - Peel and discard the release liner from the back of the faced foam.
  - Align the center of the foam with the centerline of the top wall of the cavity and then work toward the edges until the foam is centered on the inside of the top and side walls of the cavity.
  - When positioned correctly, press the foam firmly to secure it in place.
- Install the Thinsulate™ Acoustic Insulation (fig. 6)
  - Loosely line the housing with the acoustic insulation. For the best appearance, position the black side of the insulation toward the outside of the housing.
  - If there is excess insulation, overlap it against the inside of the first layer.

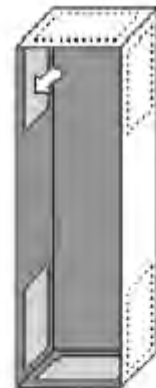

Fig. 4

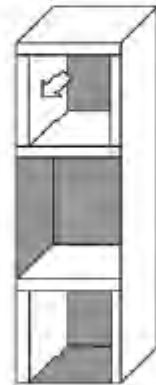

Fig. 5

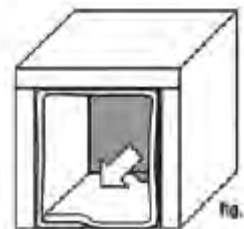

Fig. 6

# 3M™ Drive-Thru System Model G5

Additional illustrations of 3M speaker and microphone installation using the 3M Acoustic Kit and product instructions as a guideline for installation.



**Fig.1**  
Install 3M Vibration tape to metal surfaces.



**Fig.2**  
Install 3M foam and acoustic insulation.



**Fig.3**  
Solder all connections.



**Fig.4**  
Secure connections with connectors.



**Fig.5**  
Install speaker with same procedure.



**Fig.6**  
Solder all connections.



**Fig.7**



**Fig.8**

## 11. Appendix: Loop and Cable Condition Test

Measure loop inductance/resistance for each order point, recommend replacement in comments section if needed. You must conduct two separate tests on the Inductance Loop to determine it's condition:

### A. Lineal Conductor Resistance and Inductance

This test measures the Resistance and the Inductance of the loop conductor or wire at the Basestation.

#### Procedure

To measure the inductance and resistance of the loop wire, use test equipment such as an LCR meter (Inductance [L], Capacitance [C], and Resistance [R]).

A reading of 1.2 for resistance and 100–120 $\mu$ H (or 20 $\mu$ H / wire turn) for inductance are acceptable measurements that reflect good wire condition.

### B. Insulation Resistance

In addition to the factors mentioned above, ice, water, frost, etc. can contribute to the change of the conductor's resistance. However, measuring the conductor's resistance alone may not provide a complete picture, as it does not account for insulation leakage to the ground/earth. Insulation leakage can be checked by utilizing a Megohm meter (or a Megometer or Megger Meg Out, in industry parlance) capable of testing up to 500 megohms (500 million ohms).

In this test, a DC voltage is applied to the loop wire to check for insulation damage that may cause a short circuit when normal power is applied. The Meggers have settings capable of delivering anywhere from 500–1000 volts through the loop. DO NOT apply more than 500 volts for this test or you may damage the insulation. The cable's insulation is rated at 600 volts.

#### Procedure

1. Disconnect the loop wires from the loop detector so the loop is floating.
2. Place one of the meter leads to the loop wire and the other to the ground/earth.

Resistance above 20 megohms	Acceptable
Resistance below 20 megohms	Loop wire insulation has been damaged Loop integrity is questionable
Resistance less than 10 megohms	Loop wire must be replaced

## 12. Appendix: Upgrading a Single Lane Basestation to a Dual Lane

A 7-digit code is necessary in order to upgrade the software on the single lane G5 basestation to enable the dual lane capabilities. This 7-digit code is unique to each basestation and is based on the MAC IP Address. Once the 3M™ Drive-Thru System G5 Dual Lane Upgrade Package SKU#78-6911-5206-6 has been purchased, you will need to provide the following information to 3M in order to receive the upgrade code:

Customer (Store) Name:

Street address: \_\_\_\_\_ City: \_\_\_\_\_ State: \_\_\_\_\_ Zip: \_\_\_\_\_

Basestation Serial #:

MAC Address: □□ - □□ - □□ - □□ - □□ - □□

*To find the MAC address of the G5 Basestation, enter the configuration mode and choose 1 System. Then select 16 Network Setup. You will see 6 pairs of alpha-numeric characters enclosed in square brackets following the words MAC ADDRESS. Please put those 12 alpha-numeric characters in the boxes above in the order as shown on the basestation menu screen.*

3M Invoice # used to purchase the Upgrade Software: PZ

3M Invoice Date:

Once you have completed the information above, please call 3M at 800-328-0033 and select Option 1, option 3. Or you can email this information to [tacsupport@mmm.com](mailto:tacsupport@mmm.com).

After you receive the 7-digit code from 3M, go to the G5 Basestation Main Menu Screen:

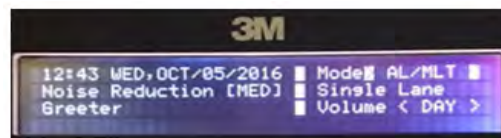

**Figure 30.**

From the Main Menu Screen:

1. Enter the 7-digit code you received from 3M on the keypad.
2. Press <MODE> key and the base station display will indicate it has been upgraded.
3. Enter the installer pass code 12345 on the keypad and press <MODE> key twice.
4. Select the SYSTEM MENU and press <ENTER>.
5. Press Arrow Down to “14 Installer Setup” and press <ENTER>.
6. Select “Save Installation Settings”, Toggle to YES and press <ENTER>.
7. Press Arrow Down to the 3rd page to “Number of Lanes at This Site”, press <ENTER>, press Arrow UP and then press <ENTER>.
8. The number of Lanes at this site will now show “2”.
9. Press <MODE> key 3 times to return to the main menu.

### Changing Your Settings

From the Main Menu Screen:

1. Enter the installer pass code 12345 on the keypad and press <MODE> key twice.
2. Select the SYSTEM MENU and press <ENTER>.
3. Select “1 Drive Thru Volume” and press <ENTER>.
4. Once settings are complete for LANE 1, press <LANE> key in order to change to LANE 2.
5. If you need to set up a Tandem Lane, Select “7 Global Settings”, switch to LANE 2 and turn on “Please Pull Ahead” Message.
6. Press <MODE> key 3 times to return to the Main Menu.



## Warranty, Limited Remedy, and Disclaimer

3M warrants that its intercom products will be free from defects in material and manufacture for the period indicated in product literature from the date of shipment to purchaser by 3M or its authorized dealer. 3M MAKES NO OTHER EXPRESS OR IMPLIED WARRANTIES, INCLUDING ANY IMPLIED WARRANTY OF MERCHANTABILITY OR FITNESS FOR A PARTICULAR PURPOSE. If the 3M intercom product does not conform to this warranty, the sole and exclusive remedy is, at 3M's option, repair or replacement of the 3M product or refund of the purchase price. This warranty does not cover: (1) the cost of shipping products to or from 3M for repair, (2) repair or replacement of existing cable or wiring, (3) product failure caused by misuse, abuse, improper installation, or unapproved modifications, or (4) intercom products that are installed or serviced by a non-3M authorized party. To obtain warranty service, please contact your authorized 3M dealer or 3M Commercial Solutions Division, 3M Center, 3M FRR, 1617 North Front Street, Bldg. 10, New Ulm, Minnesota 56073 or 1-800-328-0033.

## Limitation of Liability

Except where prohibited by law, 3M will not be liable for any loss or damage arising from its intercom products, whether direct, indirect, special, incidental or consequential, regardless of the legal theory asserted.

